

AnyFit.



AnyFit

2022

AnyFit.

ANYFIT INTERNATIONAL
Hanauer Landstr. 287-289,60314 Frankfurt am Main, DE
T +49 69 90439168
account-office@anyfit.de
www.anyfit.de
Entworfen von AnyFit Health Tech. GmbH in Frankfurt Deutschland

Business Info

AnyFit is an international enterprise focusing on fitness and health industry, it provides professional fitness and health service, products and solutions worldwide through its unique Eco-Health system and advanced technologies.

Business service includes:

- professional training technology, equipment and membership management,
- personal fitness, health service and related products.

Company Info

Established in 2014, AnyFit Health Tech. GmbH is focusing on the application of high-tech products and technologies on personal health, it is a multinational enterprise with national marketing, product R&D, manufacturing and industrial comprehensive management ability, based in Frankfurt, for the branding and European marketing promotion.

As the new and vigorous brand for fitness and health in Germany, AnyFit targeted worldwide market, with 5 years' R&D, it exhibited many times in FIBO and other international fairs with new concept, where it was highly approved by clients. In 2022, AnyFit will bring mature and systematized products to the market.



CONTENT

CARDIO	01
AI SERIES	01
TREADMILL	11
ELLIPTICAL	21
STAIRTRAINER	31
UPRIGHT BIKE	43
PULSE P	51
STRENGTH	57
PISTON-E	71
PISTON-S	85
TITAN	91
SPECIFICATION	99
SERVICE GUARANTEE	109

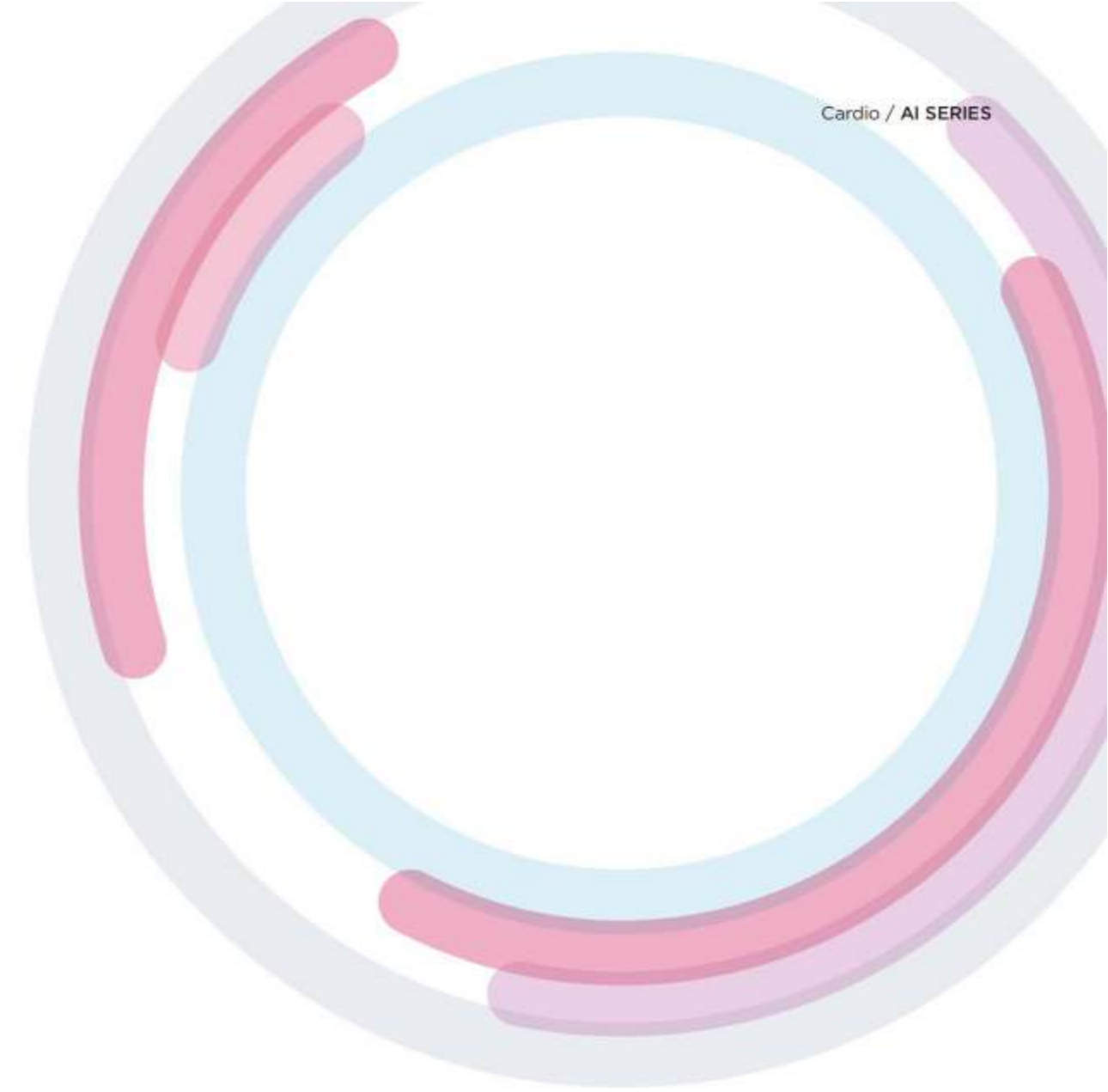

AI SERIES

APPEARANCE DESIGN

Extraordinary craftsmanship

Less is More.

In order to pursue the minimalist movement of the exterior, the surface design of the machine pursues a refined and clean visual effect. Using the internal fixed design to keep the perfection of the surface to the greatest extent, we adopt a special mold process to make the line sharper, reaching R0.2mm, which is equivalent to the standard of consumer electronics. Not only does this show the minimalism and high quality concept of AnyFit, it also expresses the sports spirit of infinite breakthrough.

Double Texture Appearance

Alternating glossy and matte textures. Focus on the expression of smooth lines and exquisite craftsmanship



Appearance Patent

Unified systematic style design, appearance patent.



With AnyFit Smart Training Tech.

FUNCTIONAL DESIGN



Smart ID

Smart bracelet and scan code, automatically logged in.
Smart identification of membership

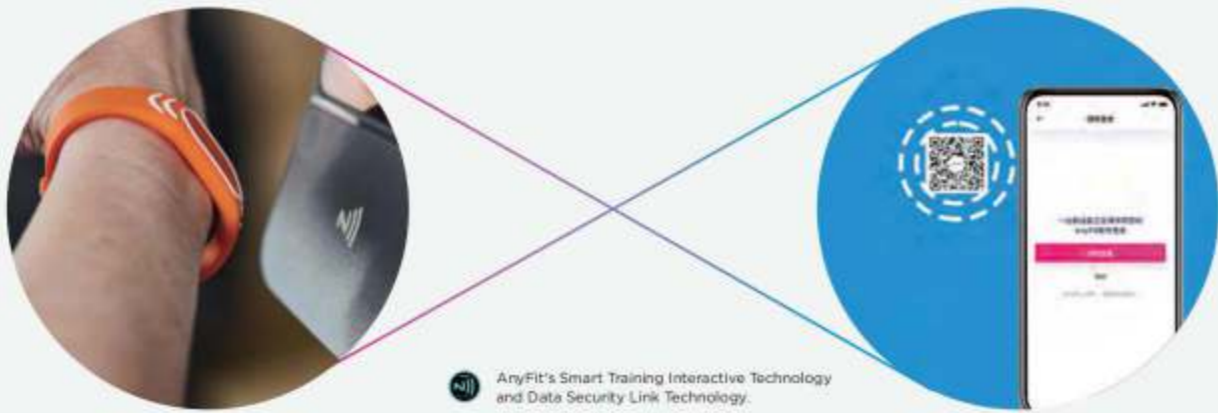

Smart Personal Training

Check out the exclusive plan for coach customization.
Adjust the intensity of the plan at any time according to your own situation.

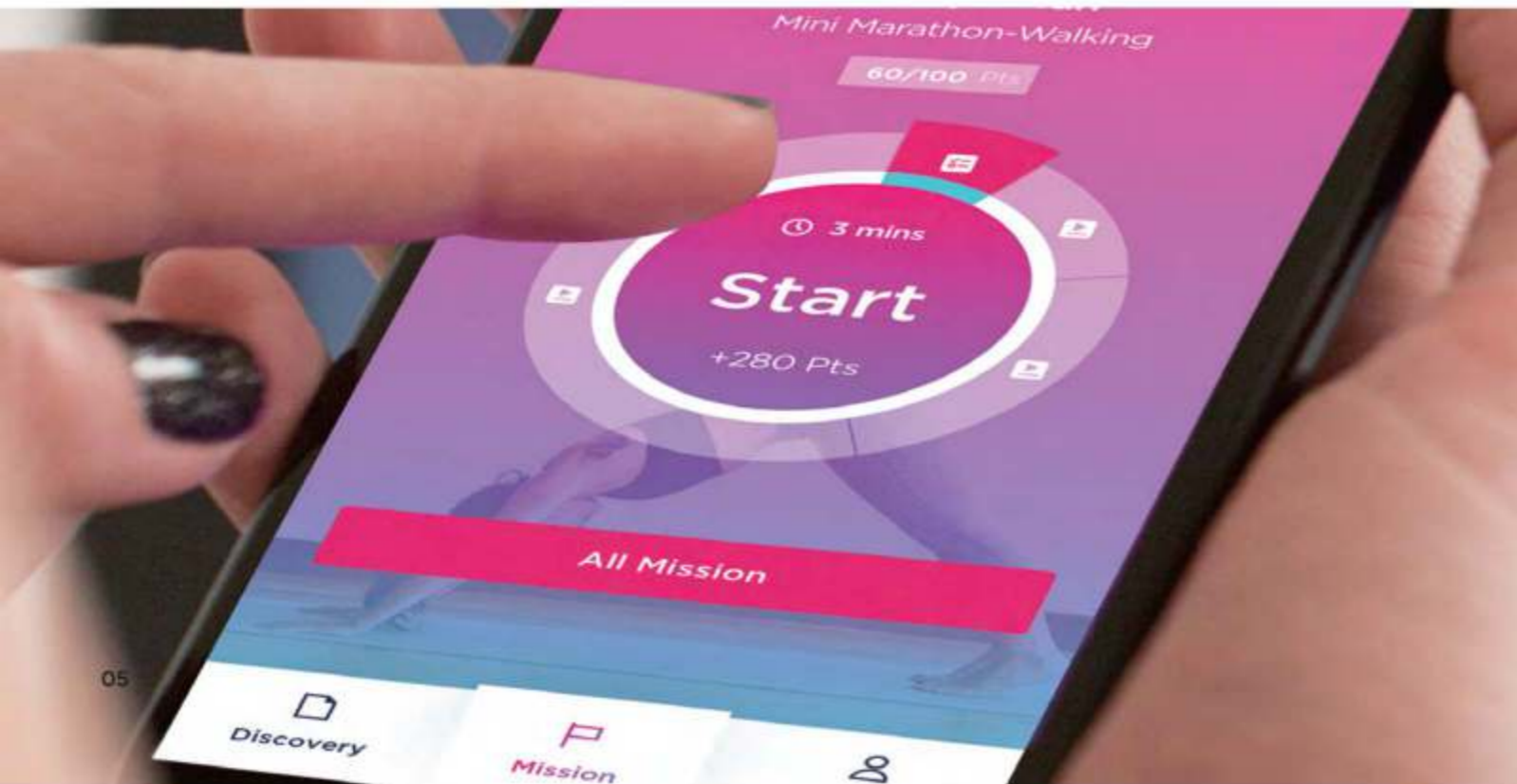

Smart Curriculum

Flexible online courses, continually updated, even including group running course, depending on the personal trainer.



Smart Data Statistics

History of statistics, view the completion of the course, daily smart training data analysis; personal health management, physical analysis and fitness level assessment, statistics of various body data.



Synchronous detection of heart rate

It provides an objective exercise scale for your heart rate, because it is usually more accurate and safer than your feelings.



VIRTUAL REALITY

SCENERIES FROM THE WORLD,
IMMERSIVE ENJOYMENT.



Entertainment

Enjoy the latest music, watch Hollywood movies online, browse the news, engage in social media.



Lights Language



Successfully loaded, the green light is on, start your new training.



When activated and checked, the LED light turns green. Blue light means fitness stations can be used. Red light means log out.

Before and after training, light language is safe and visible. Every design detail is combined with function and aesthetics.



Heart Rate



TREADMILL

With Anyfit Smart Training Tech.



SIMPLY BETTER

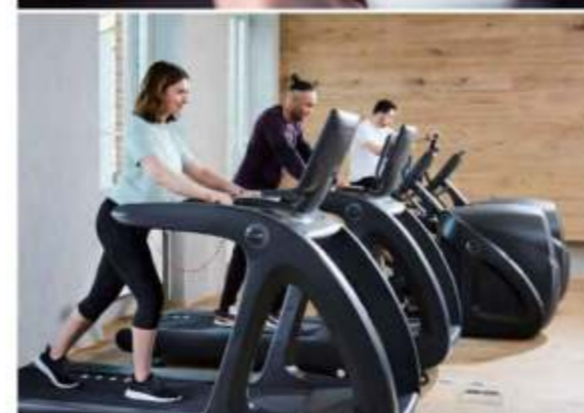

The treadmill is not new product, running is not a new way of exercising.

How to innovate is a key challenge for us, as we want to be different.

We all have no choice but to be better. We need to be stronger, so our treadmill's overall structure is more stable, and thousands of tests are enough to prove it. We need to be smarter, so it is equipped with the AnyFit smart training system, which makes running more suitable for everyone's ideas and needs.

Sometimes less is more, so with our smooth appearance and exquisite craftsmanship we pursue to stand out.

Any way, we simply need to be better.

COMFORT DESIGN

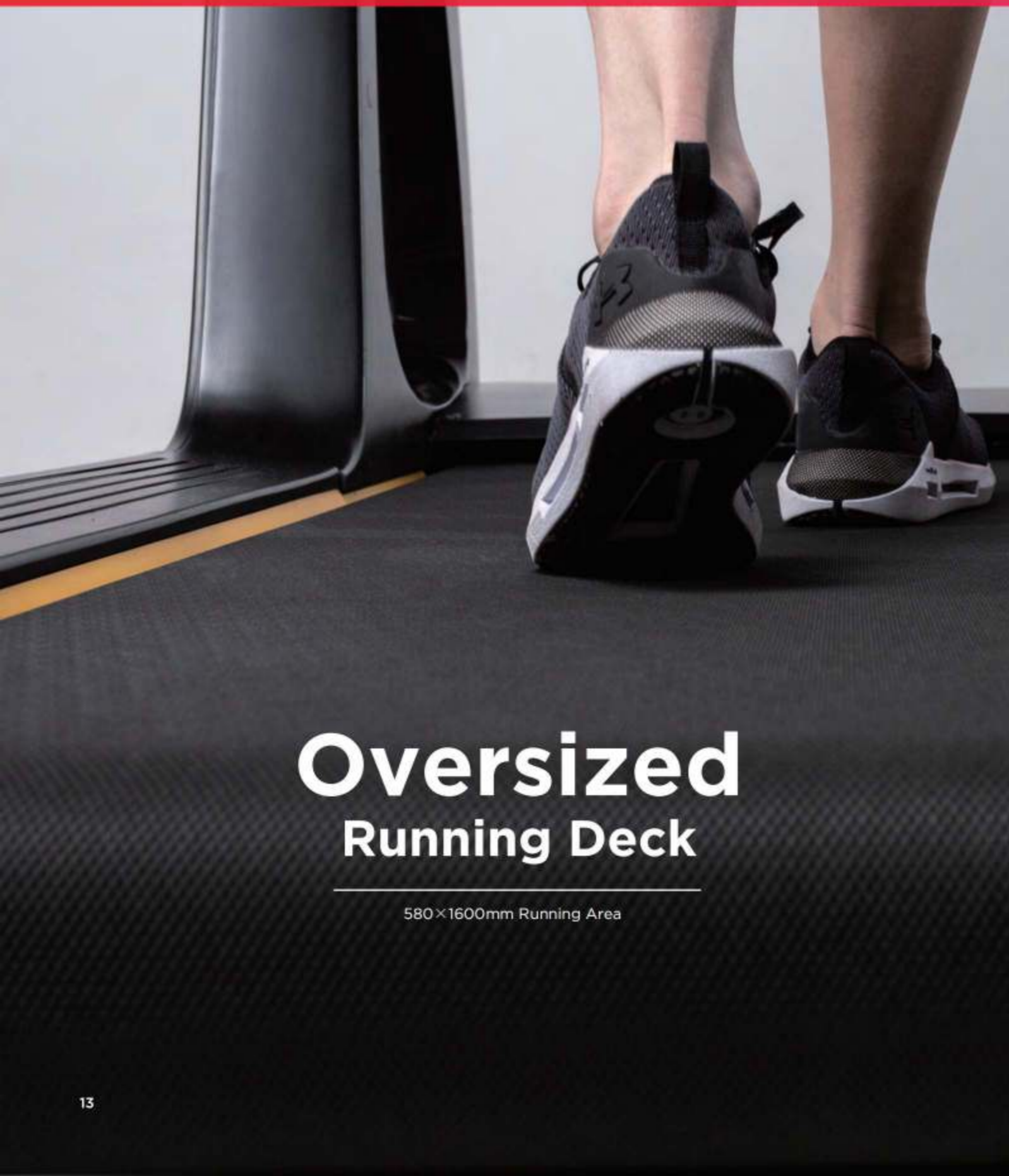

Oversized Running Deck

580×1600mm Running Area

Comfortable Running Height

The running height of the running platform is lower than the usual running platform 30-40mm



Ergonomic Handrail

Double-shot moulded TPR material, soft to the touch



Triangular Column

The unit is more stable during running.

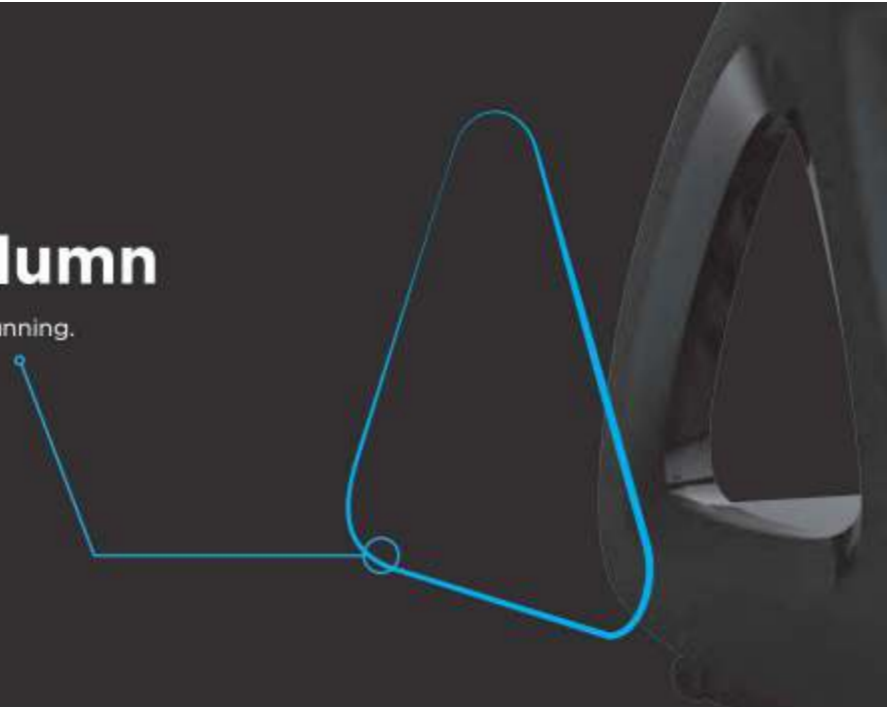

Introversion Sidebar

The side strips are designed with an inward tilt.



Smooth Running

Brings users a superior and flexible running experience

PERFORMANCE



Speed

The fastest speed can reach **24km/h**, provides smooth, consistent, natural exercise experience



High Performance Motor

Efficient **3.0 kW** AC precision motor with a top speed of **24km/h** for a smooth, consistent, natural workout experience.



Maintenance Free Running Deck

Maintenance-free design with running belt, no lubrication required



HD Smart Screen

1080P 21.5 inch screen, tempered glass, high strength, high resistance, large screen brings the feeling of being there

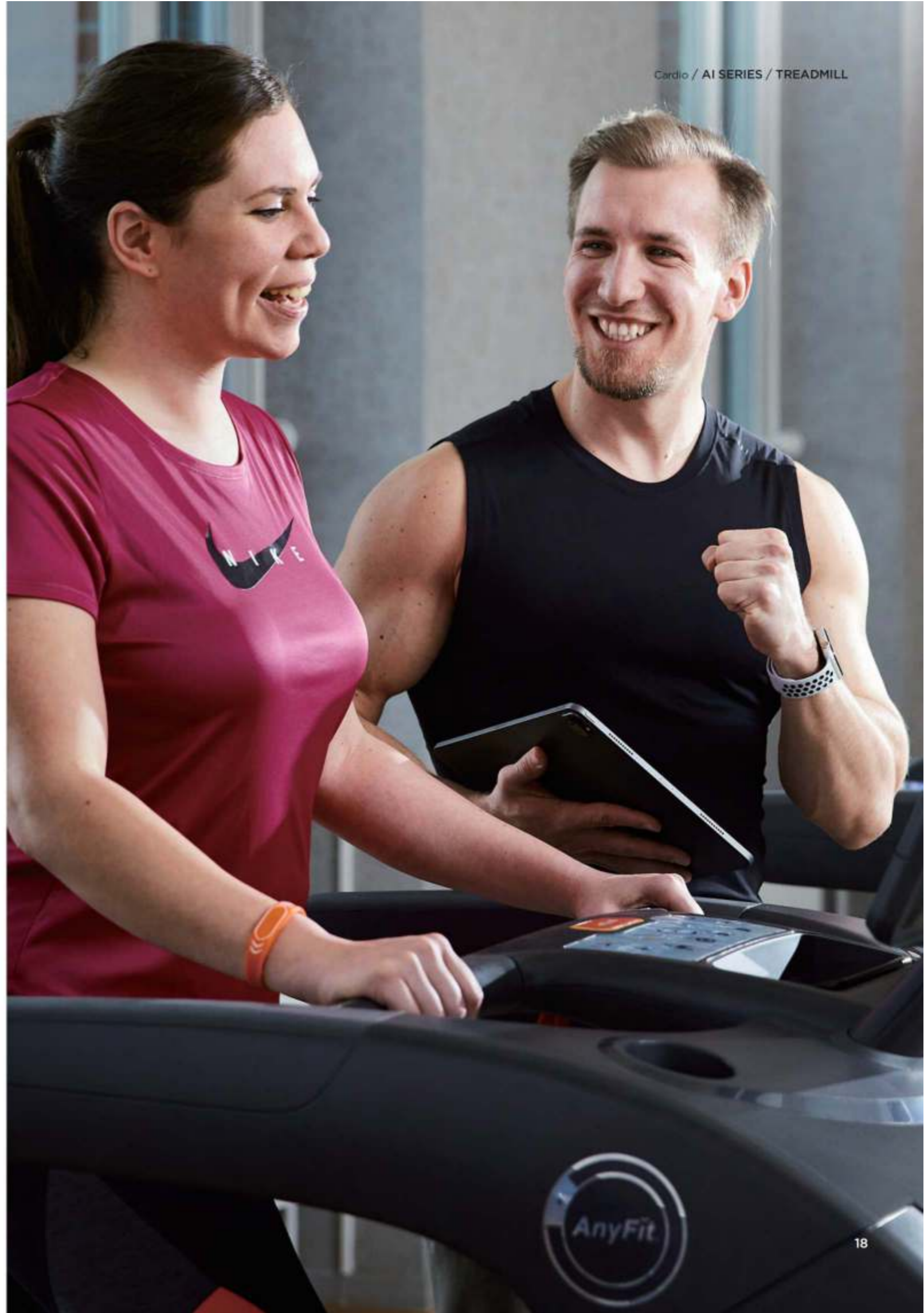

AnyFit Course

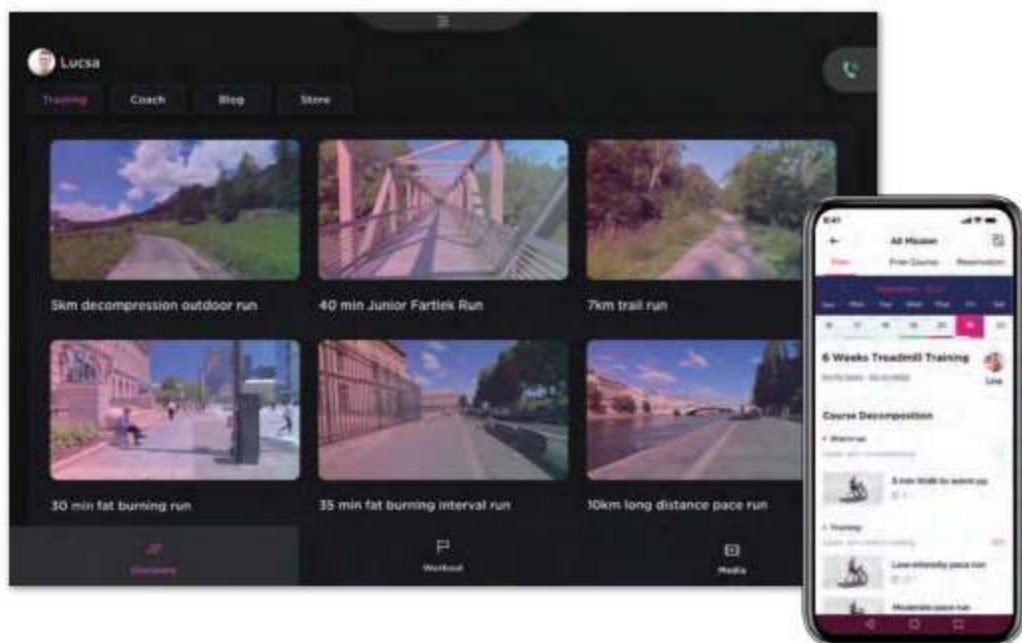

Specifications	AI5	AI3
Console Screen	21.5" Touchscreen	0.56" Led+8*8 Dot Matrix
Motor Power	3.0KW	3.0KW
Speed	1-24KM/H	1-24KM/H
Incline	0-15%	0-15%
Running Surface	580*1600mm	580*1600mm
Assembled Dimension	2220*910*1600mm	2220*910*1600mm
Self-compiled programs	3	3
Preset Programs	6	6
Power Requirements	AC 220V/110V	AC 220V/110V
Net Weight/Gross Weight	240KG	240KG
Max User Weight	150KG	150KG
Console Function		
USB	•	○
Headphone	•	-
Fan	•	•
Multiple Cup And Accessory Holders	•	•
Bluetooth Audio Output	•	-
Console Data Display		
Speed	•	•
Incline	•	•
Speed Shortcut Key	•	•
Slope Shortcut Key	•	•
Calories	•	•
Heart Rate	•	•
Distance	•	•
Time	•	•
Frequency	•	•
Power Ration	•	•
Remaining Time	•	•
Elapsed Time	•	•
Total Progress Time	•	•
Rotations Per Minute	•	•
Average Speed	•	•
METS	•	•
Preset Program	•	•
Self-compiled	•	•

ELLIPTICAL

With Anyfit Smart Training Tech.

COMPLETELY DIFFERENT CONCEPT

Using an elliptical and unique design concept, AnyFit occupies global design patents and multiple structural patents. All the design and investment ensure a smooth experience during movement without any breaks. Also with smart training, difference of height of user and necessary needs for training courses.

For the mechanical design in the transmission structure part, we use 76 bearings, 3 special motors. The manufacturing process is also subject to strict quality control.

With AnyFit smart training technology, each user can be matched with the most suitable mechanical mode. According to the personal body data, after logging in, the device will automatically adjust the height and stride of the first step, this is a unique innovation in AnyFit's multi-function elliptical design.



COMFORT DESIGN



Reasonable Pedal Spacing

The **6.4cm** pedal spacing is designed after the analysis of a large number of people. Suitable for different trainers, ultimate sports comfort

Smart Stride Adjustment

According to the different heights of the trainers, the length of the stride is automatically matched, and the stride adjustment range is **50-69 cm.**



Smart Step Depth Adjustment

Automatically adjust the depth of the foot according to the training plan, Suitable for different training methods.

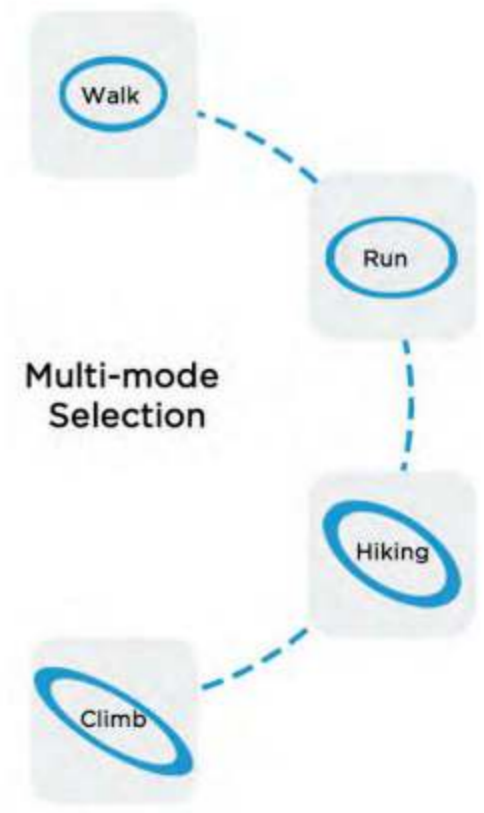

Multi-position Sports Handrail

Designed for by different training methods and heights of trainers. Make the training posture more diverse and comfortable.





Large Pedal

According to different population data, comfortable rubber material is used, making your movements more pleasant.

Smooth Track

Smooth trajectory, no break.

76 bearings, **3** special motors, the manufacturing process is also subject to strict quality control



PERFORMANCE



HD Smart Screen

1080P Screen, Tempered glass, High strength, High resistance, Panoramic large screen, brings you the feeling of being there.

Humanized Design



Fan



Bluetooth Audio Output



Storage Box



USB interface



Ipad/Mobile phone slot

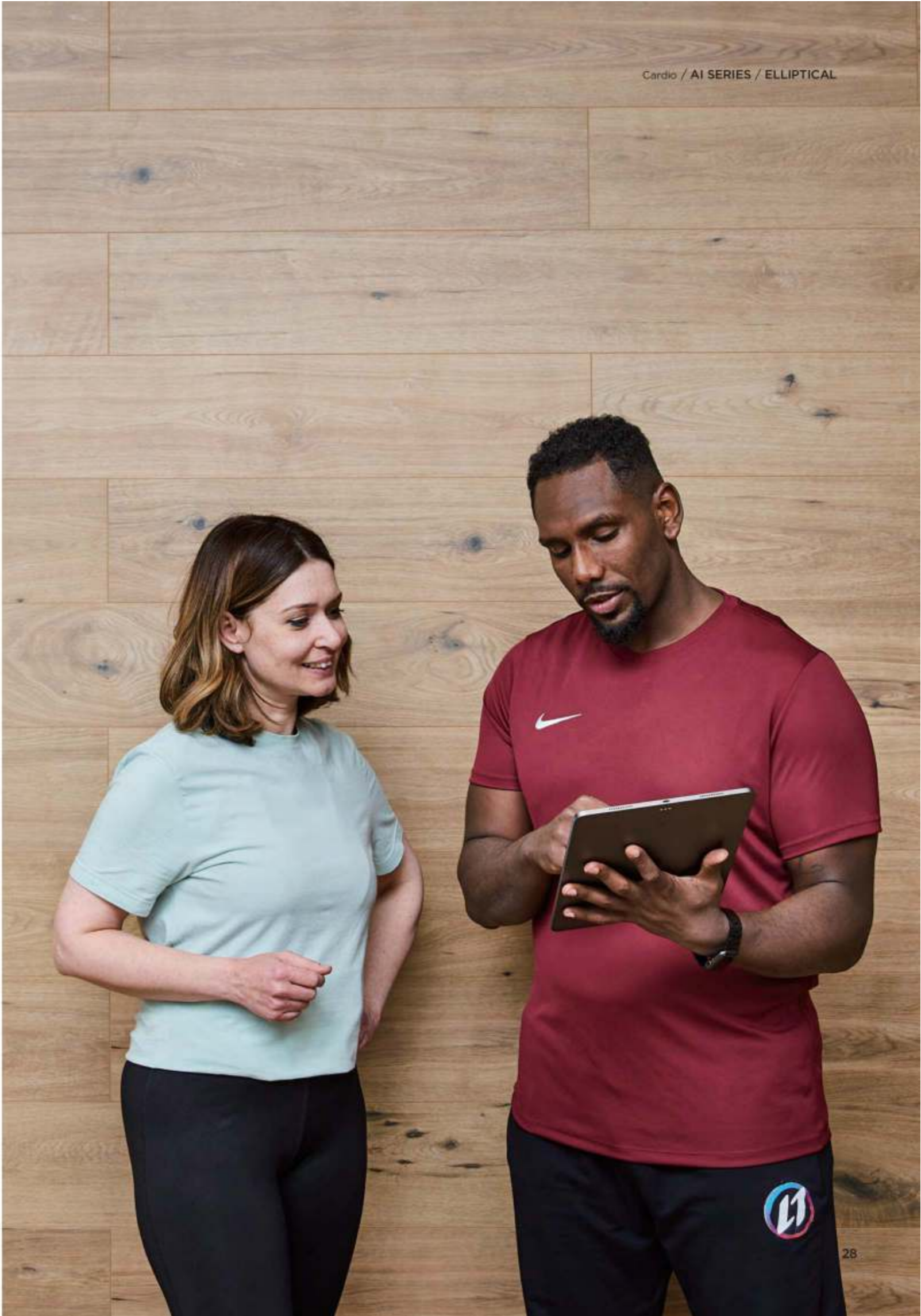

AnyFit Course

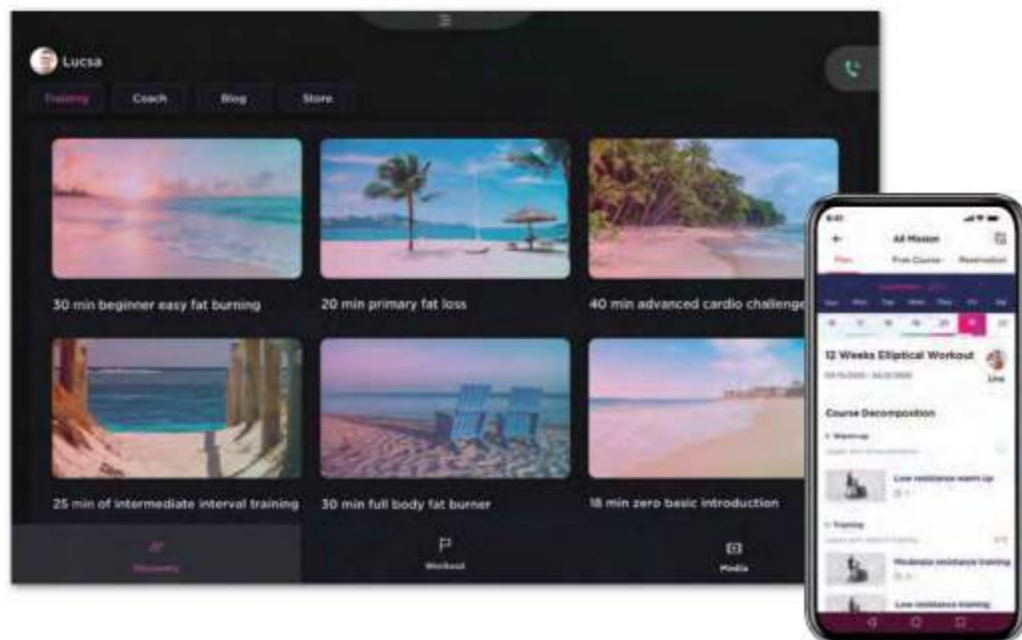

Specifications	AI5	AI3
Console Screen	10.1" Touchscreen	0.56" Led+8*8 Dot Matrix
Resistance Level	1-25	1-25
Stride Grade	1-10	1-10
Step Depth Grade	1-15	1-15
Stride Adjustment Length	481-637mm	481-637mm
Step Depth Adjustment Length	435-561mm	435-561mm
Pedal Center Distance	230mm	230mm
Self-compiled Programs	1	1
Preset Programs	6	6
Power Requirements	AC 100V~240V 50/60Hz	AC 100V~240V 50/60Hz
Assembled Dimension	2120*790*1680mm	2120*790*1680mm
Net Weight/Gross Weight	225/310KG	225/310KG
Max User Weight	150KG	150KG
Console Function		
USB	•	○
Headphone	•	-
Fan	•	•
Multiple Cup And Accessory Holders	•	•
Bluetooth Audio Output	•	-
Mobile and Pad Holders	•	•
Console Data Display		
Resistance Level	•	•
Stride Adjustment	•	•
Step Depth Adjustment	•	•
Speed	•	•
Rotations Per Minute	•	•
Average Speed	•	•
Calories	•	•
Heart Rate	•	•
Distance	•	•
Time	•	•
Frequency	•	•
Power Ration	•	•
Remaining Time	•	•
Elapsed Time	•	•
Total Progress Time	•	•
Preset Programs	•	•
Self-compiled programs	•	•
Function Feature		
Smart Stride Adjustment	•	•
Smart Step Depth Adjustment	•	•
Multiple Position Handrails	•	•
Quick Adjustable Handrail	•	•
Transport Wheel	•	•

STAIRTRAINER

With Anyfit Smart Training Tech.

MORE NATURAL & LASTING

Walking, running, jumping, and climbing are the most natural and popular exercise ways.

Training equipment lets users get close to the most basic and natural movement, but this is not a simple subject. Not only must safety always be ensured while training, but also comfort and sustainability. The clear design leaves space for unlimited upgrading of the equipment.

The natural design is the core of our Stairtrainer, resulting in an overall larger size and wider pedal. Every design should meet a comfortable and natural exercise experience of users' feet, legs and upper body. Only then, the movement can be more lasting.

Our goal is simple, If someone asked, why use the StairTrainer? They would say: Because it is an AnyFit StairTrainer.



COMFORT DESIGN

Wider Pedal

Brings more comfortable space, suitable for different posture training, make training more flexible.

Easily stepped into

Floor-standing pedal design, easier to step in.

Easier Workout

The Stairtrainer always comes to a standstill after training and keeps half a step on stand-by which provides an easier reentry.



Soft Side Handrail

Soft material, more comfortable grip.



Flexible Grip Options

Designed for different training methods and heights of trainers. Make the training posture more diverse and comfortable.



Three-steps Operation

The training area always provides three steps.





- **Unique bivariate adjustment training, setting the degree of difficulty based on different training needs.**



A - Resistance Training: self-adaptive weight
(to increase and decrease resistance through resistance adjustment)



B - Speed Training
(to reduce and increase speed through resistance adjustment)

- **Self-adaptive weight**



Adapts to the initial boarding speeds of different trainers.

SAFETY



Wraparound Handrails

Safer for users

Embedded Security Identification

Orange warning design makes training safer



Patented Emergency Stop

The device will come to a standstill when the emergency stop button is pressed, to ensure safety at all times

Anti-pinch Step

Unique design lets the trainer focus on their training more focused on training



Safety Assisted Side Step

Can be used to take a short break, one-leg training is also possible. Combine with the training program to complete more actions.

PERFORMANCE



HD Smart Screen

1080P Screen, Tempered glass, High strength, High resistance, Panoramic large screen, brings you the feeling of being there.

Humanized Design



Fan



Bluetooth Audio Output



Storage Box



USB Interface



ipad/mobile Phone Slot



Transmission System

Chain drive, Stainless steel, stronger.

Handrail Button

Matching ergonomic design with quick adjustment of the armrests, easy to adjust.



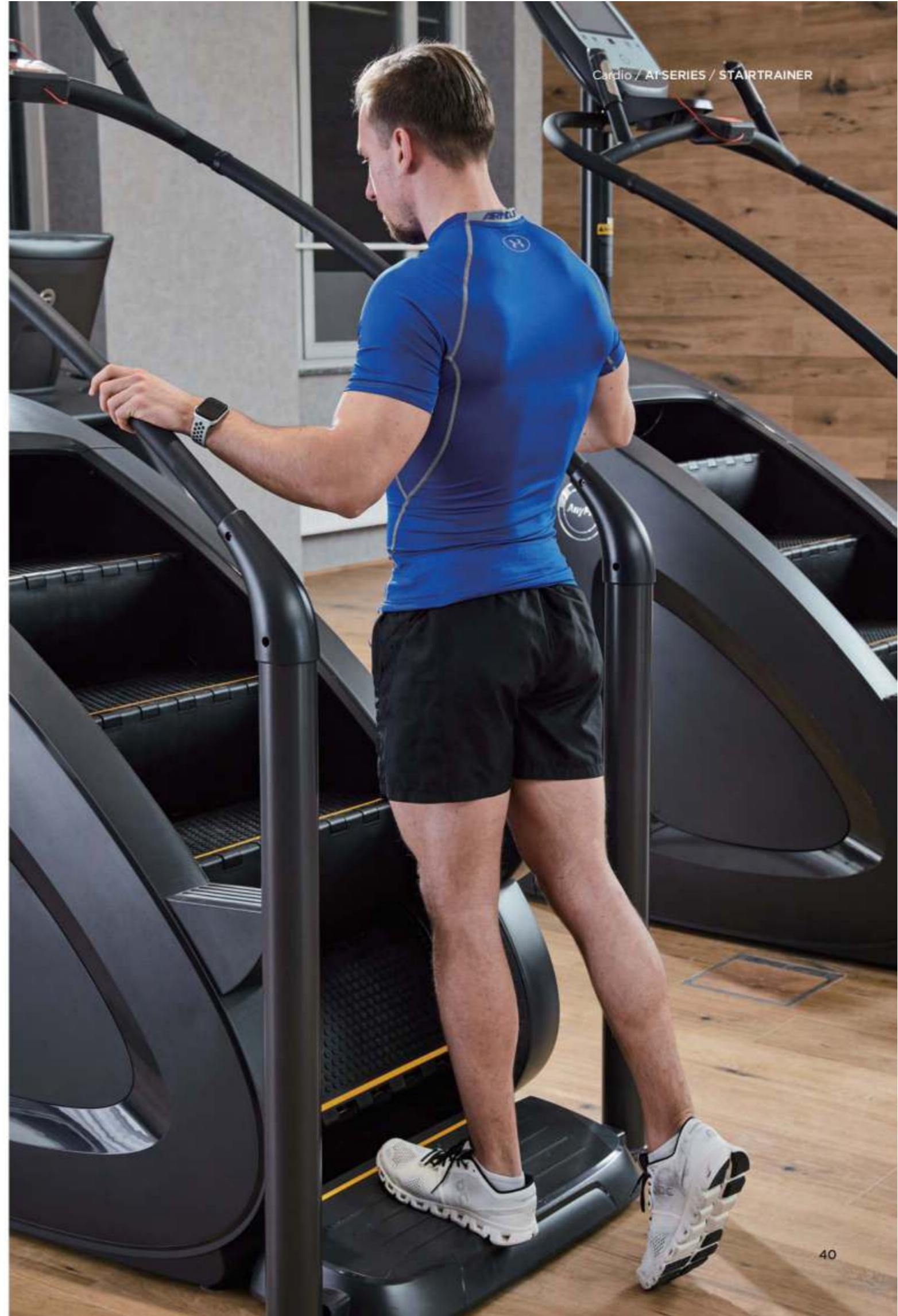

AnyFit Course

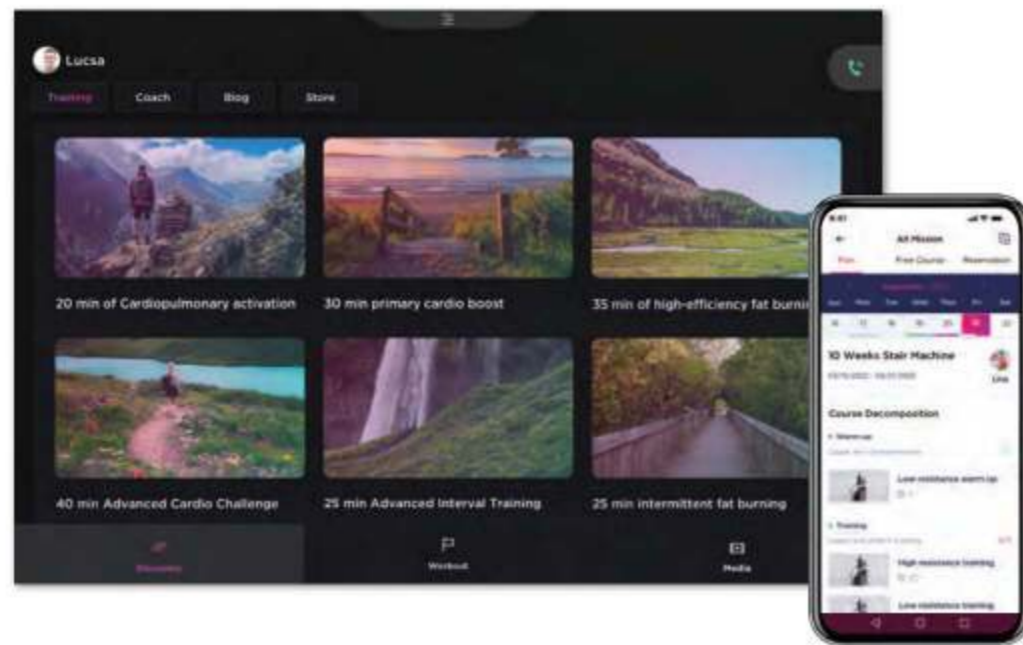

Specifications	AI5	AI3
Console Screen	10.1" Touchscreen	0.56" Led+8*8 Dot Matrix
Resistance Level	1-20	1-20
Staircase Dimension	550*278*205mm	550*278*205mm
Initial Stair Height	300mm	300mm
Effective Utilization Staircase	3	3
Self-compiled Programs	1	1
Preset Programs	6	6
Power Requirements	AC 100V ~ 240V 50/60Hz	AC 100V ~ 240V 50/60Hz
Assembled Dimension	1600*970*2230mm	1600*970*2230mm
Net Weight/Gross Weight	226/310KG	226/310KG
Max User Weight	150KG	150KG
Console Function		
USB	●	○
Headphone	●	-
Fan	●	●
Multiple Cup And Accessory Holders	●	●
Bluetooth Audio Output	●	-
Mobile and Pad Holders	●	-
Console Data Display		
Resistance Level	●	●
Speed	●	●
Rotations Per Minute	●	●
Average Speed	●	●
Calories	●	●
Heart Rate	●	●
Distance	●	●
Time	●	●
Frequency	●	●
Power Ration	●	●
Remaining Time	●	●
Elapsed Time	●	●
Total Progress Time	●	●
Preset Programs	●	●
Self-compiled Programs	●	●
Function Feature		
Safety Side Step	●	●
Easily Stepped Into	●	●
Patent-Emergency Stop	●	●
Multiple Position Handrails	●	●
Quick Adjustable Handrail	●	●
Transport Wheel	●	●

UPRIGHT BIKE

With Anyfit Smart Training Tech.



NO MORE BEING ALONE

Some people like running training, others like riding. We are all passionate about one of them, so are the members. Therefore, it is necessary to have them all, but the utilization rate is not high. How to make the necessary things more important?

The intelligent exercise bike equipped with anyfit intelligent training technology can make members like combined training through the arrangement of intelligent fitness courses. Through the guidance of the course plan, members can try more fun of training with running and fitness bike, and even integrate more training forms, such as FTP test. Or with electrical pulse training (EMS), the training process and challenges can become infinite and interesting.



Easily Adjust Seat Height

With its 14 seat adjustment levels, the adjustment switch is located below the seat. Easier to adjust, the seat height can be easily adjusted even if you are riding.



Multi-position Sports Handrail

Designed for different training postures, the handrail makes the training posture more diverse and comfortable.

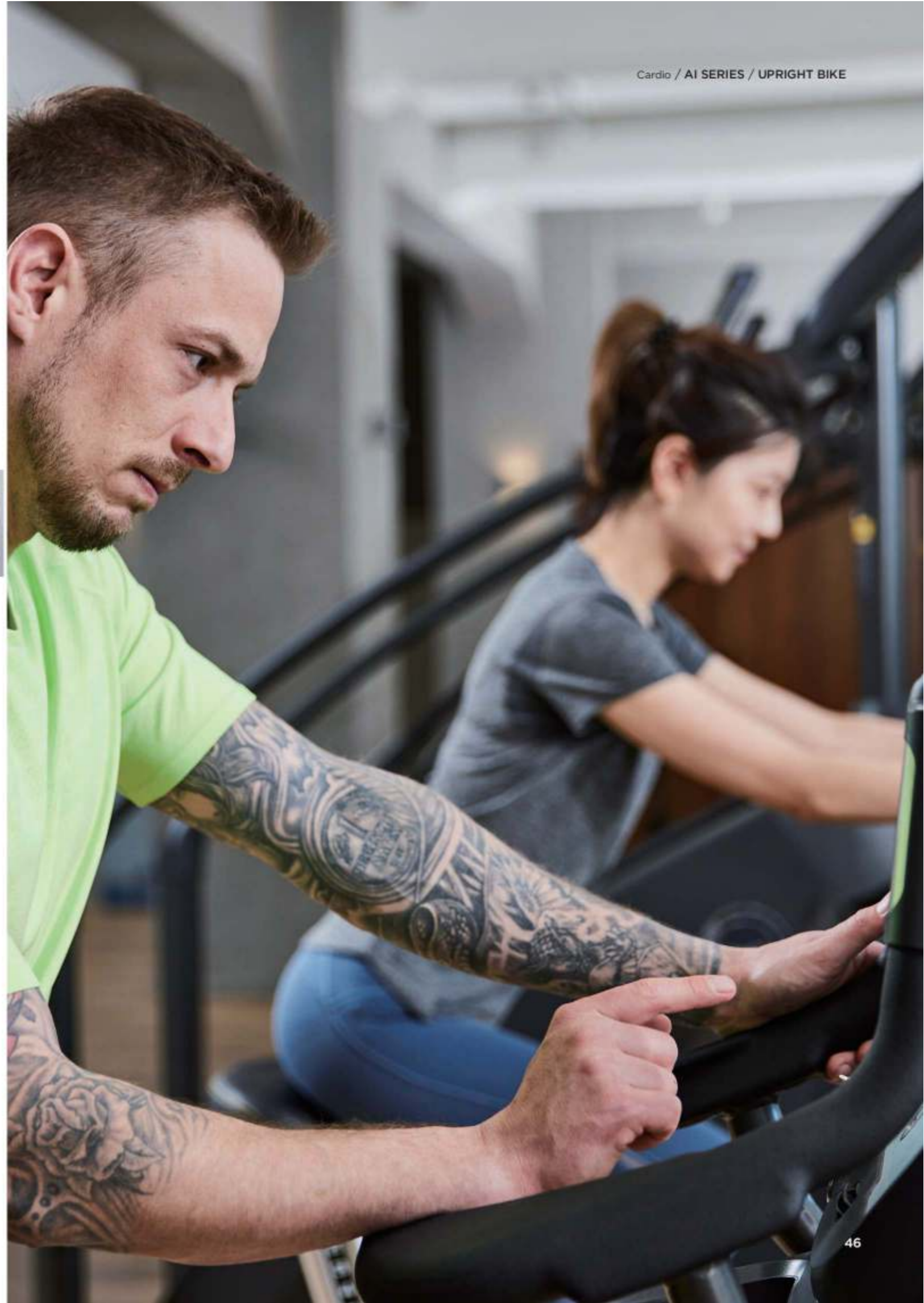



Handrail Button

Matching ergonomic design, easy to adjust the armrest, easy to operate.

HD Smart Screen

1080P screen, tempered glass, high strength, high resistance, large screen brings you the feeling of being there.

Belt Drive

The belt drive system designed from the user's point of view is quiet and comfortable, making your fitness more relaxed.

Reasonable Crank Angle

The crank and pedal cling to the body of the device, device and bring you a real riding experience.



Specifications	AI5	AI3
Console Screen	10.1" Touchscreen	0.56" Led+8*8 Dot Matrix
Resistance Level	1-25	1-25
Self-complied Programs	1	1
Preset Programs	6	6
Power Requirements	AC 100V~240V 50/60Hz	AC 100V~240V 50/60Hz
Assembled Dimension	1200×500×1450mm	1200×500×1450mm
Net Weight/Gross Weight	75/95KG	75/95KG
Max User Weight	150KG	150KG
Console Function		
USB	•	○
Headphone	•	•
Fan	•	•
Multiple Cup And Accessory Holders	•	•
Bluetooth Audio Output	•	•
Mobile and Pad Holders	•	•
Console Data Display		
Resistance Level	•	•
Speed	•	•
Rotations Per Minute	•	•
Average Speed	•	•
Calories	•	•
Heart Rate	•	•
Distance	•	•
Time	•	•
Frequency	•	•
Power Ration	•	•
Remaining Time	•	•
Elapsed Time	•	•
Total Progress Time	•	•
Preset Programs	•	•
Self-complied Programs	•	•
Function Feature		
Multiple Position Handrails	•	•
Quick Adjustable Handrail	•	•
Adjustable Pedal	•	•
Adjustable Seat	•	•
Transport Wheel	•	•

PULSEP

**VIBRATION TRAINING
HAS NEVER BEEN
THIS EASY**





3D Vibration

Built-in 3D motor, 3D high-frequency vibration of 30-50Hz per second.



AnyFit Lights Language

When activated and checked, LED light turns green.
Blue light means fitness stations can be used.
Red light means log out.

Before and after training, light language is safe and visible. Every design detail is combined with function and aesthetics.

Smart Training with App

Launch mission course for training with an App which helps you with all the details. you for all training details. Ask your trainer for a speed training plan or take part in smart group trainings in your studio.



Measurement (W x L x H)	650 x 640 x 215 mm
Weight	39 kg
Maximum user weight	120 kg
Vibration area	650 x 640 mm
Vibrationplate thickness	5,8 mm
Vibration frequencies	30-50 HZ, 1Hz gradually
Vibration speeding up	Factor 1-5
Display measurement	LED
Data transfer	Phone - Display
Preset programs	Strength \ Stretch \ Massage \ Relax

 AnyFit's Smart Training Interactive Technology and Data Security Link Technology.

 AnyFit's Smart Training Interactive Technology and Data Security Link Technology.



PISTON

With Anyfit Smart Training Tech.



Piston is a series focused on training results. The key point of design is precision ergonomics, including: precise degree design, defined movement and smoother path of motion, which aim to achieve accurate stimulation of muscles.

This is also the AnyFit smart training technology, which makes it possible to monitor the process and collect accurate data.

COMFORT DESIGN

Easy and Adjustable Seat Height

The seat and back pad can be adjusted according to the range of motion to match users with different heights



Special Multilayer Foaming Material



- **More Durable**

The Upholstery is comfortable and durable. Long-lasting use without damage.

- **Pleasant Appearance**

Same as car seat cushion quality. More comfortable and beautiful, available in a variety of colors and materials for customers selection.

- **Anti-sweat, Antibacterial**

Passed the anti-sweat penetration test, with good anti-sweat performance and antibacterial effect.

The Color Option



GALAXY GREY FRAME

BROWN UPHOLSTERY



WHITE FRAME

BLACK UPHOLSTERY



WINE RED FRAME

CHARCOAL UPHOLSTERY



Within program: distance / route, adjustments and adaptations



Interactive guidance of training programs



SELF TRAINING

Independent Strength Training

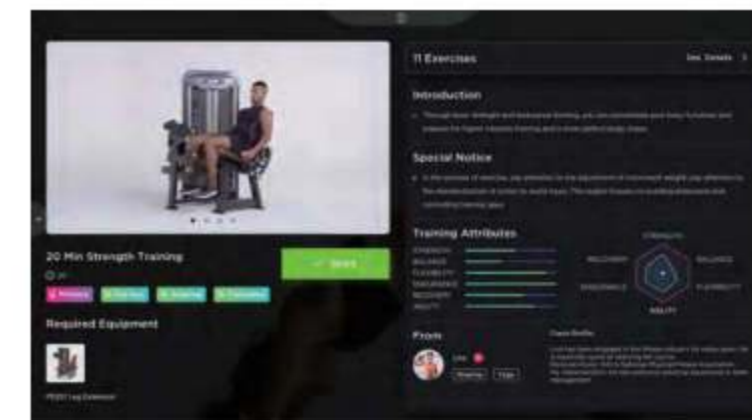



Smart ID

Smart bracelet and scan code, automatically login.
Smart identification of membership



AnyFit's Smart Training Interactive Technology
and Data Security Link Technology.

10.2" Touchscreen

A panoramic big screen gives you a
feeling of actually being there.



PISTON 5



AnyConnect

PISTON 3



APP Workout



Smart Private Trainer

All members of the AnyFit Eco-Fitness Studio can have their workout within the individual training program which is preset on the smart equipment by their private trainers, to achieve smart mission control at anytime.

Any Part of the Limbs Can Be Trained Individually

1. Limb training is more various.
2. More ergonomic requirements, relative linkage, split-type training in the target muscles leading to a more efficient training process.



FUNCTIONAL DESIGN

Precise Machined Pulley

Compared with common pulleys our pulley is added another machined processing. This results in:

1. Better performance and durability
2. Smoother path of motion.

After thousands of times testing and adjustment, it is safe to say the pulley keeps vibration and swing deviation at **0.1mm**. This is extremely difficult and ensures the core muscles and small muscle groups exercise while minimizing the risk of sports injury workout.

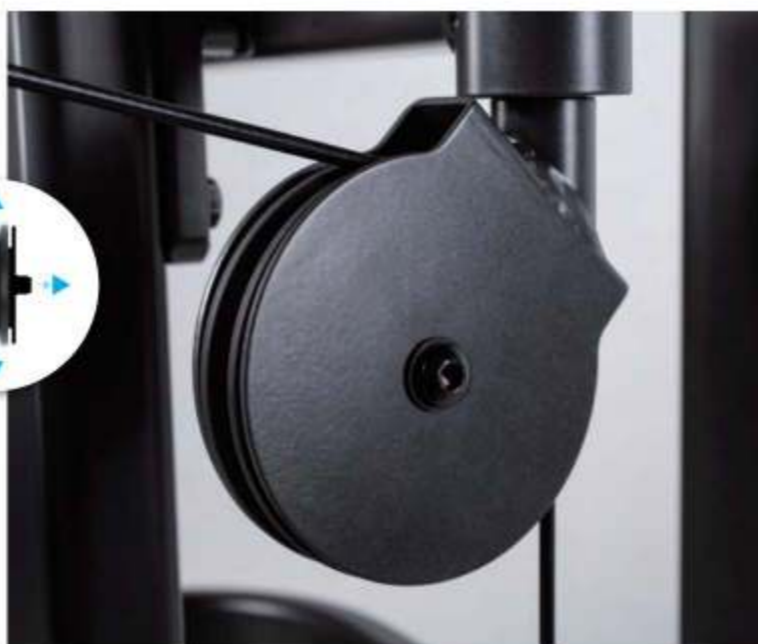

Shield

3mm ABS shield is made by AnyFit one shot technology with high resistance and impact, provides privacy and safety. The structure with the steel frame makes assembly easier. The repair and replacement becomes very convenient.



Cable

As is known to us, cable is the most vulnerable part of strength equipment, which determines the life time of equipment. We provide optional EXERFLEXPRO (option) cable from the U.S. to ensure a positive workout experience and unparalleled safety. And we tested the cable in our lab, it reaches **400,000** times without break in normal use, which is **4** times more than the ordinary cable. The safe usage of our sports equipment can be guaranteed for **2** years in normal use. This greatly reduces replacement and the risk of damage, extends the life of the equipment and saves half of the cost of maintenance.



Bearing

We use Model#TPI6205 bearings, which have higher quality than others. Large size bearings can ensure better rotation stability, improve training stability and have longer life time.





PISTON-E SERIES



Chest Press

PE101

Standard Weight Stack: 96 kg/212 lbs
 Optional Weight Stack: 123 kg/271 lbs
 Assembled Dimension: 122.5X147.7X179.6cm
 Net Weight: 165 kg

- Converging axis arms bring natural and soft movement, and an increased exercise variety.
- Super-sized grips reduce pressure when pressing.
- The whole series are equipped with professional stable feet for safety.
- Professional and precise ergonomic design of training angles.
- Strong and durable aluminum alloy shield frame.
- Equipped with convenient cup and cellphone holder.
- Separable structure design for easy packaging and transportation.
- Protective end design of the handlebar for safety of the movement.

Pulldown

PE104

Standard Weight Stack: 96 kg/212 lbs
 Optional Weight Stack: 123 kg/271 lbs
 Assembled Dimension: 166.8X125.4X193 cm
 Net Weight: 162 kg

- Adjustment points are highlighted with a contrasting color for ease of use.
- Dual-position hand grips allow for greater training variety.
- Super-sized grips reduce pressure when pulling down.
- The whole series are equipped with professional stable feet for safety.
- Professional and precise ergonomic design of training angles.
- Strong and durable aluminum alloy shield frame.
- Equipped with convenient cup and cellphone holder.
- Separable structure design for easy packaging and transportation.
- Protective end design of the handlebar for safety of the movement.



Shoulder Press

PE102

Standard Weight Stack: 66 kg/212 lbs
 Assembled Dimension: 162.4X159.2X159.6 cm
 Net Weight: 170 kg

- Dual-position hand grips allow for greater training variety.
- Reclining seat position allows for better posture and back support.
- Converging axis arms bring natural and soft movement, and an increased exercise variety.
- Super-sized grips reduce pressure when pressing.
- The whole series are equipped with professional stable feet for safety.
- Professional and precise ergonomic design of training angles.
- Strong and durable aluminum alloy shield frame.
- Equipped with convenient cup and cellphone holder.
- Separable structure design for easy packaging and transportation.
- Protective end design of the handlebar for safety of the movement.



Dip/Chin Assistant

PE105

Standard Weight Stack: 141 kg/311 lbs
 Assembled Dimension: 158.8X131.6X251.6 cm
 Net Weight: 140 kg

- Dual grips for added exercise variety.
- Footbar easily flips up for unassisted pull-ups and dips.
- Super-sized, dual position grips reduce pressure when pressing and create different hand positioning.
- The whole series are equipped with professional stable feet for safety.
- Professional and precise ergonomic design of training angles.
- Strong and durable aluminum alloy shield frame.
- Equipped with convenient cup and cellphone holder.
- Separable structure design for easy packaging and transportation.
- Protective end design of the handlebar for safety of the movement.

Seated Row

PE107

Standard Weight Stack: 96 kg/212 lbs
 Optional Weight Stack: 123 kg/271 lbs
 Assembled Dimension: 193X111.5X160 cm
 Net Weight: 155 kg



- Diverging path of motion invites a complete range of movement for optimal training results.
- The whole series are equipped with professional stable feet for safety.
- Professional and precise ergonomic design of training angles.
- Strong and durable aluminum alloy shield frame.
- Equipped with convenient cup and cellphone holder.
- Separable structure design for easy packaging and transportation.
- Protective end design of the handlebar for safety of the movement.

Converging Chest Press

PE109

Standard Weight Stack: 96 kg/212 lbs
 Optional Weight Stack: 123 kg/271 lbs
 Assembled Dimension: 140X130X160 cm
 Net Weight: 158 kg



- Independent converging arm movements provide a natural path of motion and increase exercise variety.
- Super-sized grips reduce pressure when pressing.
- Designed for easy entry and exit.
- Strong and durable aluminum alloy shield frame.
- Equipped with convenient cup and cellphone holder.
- Separable structure design for easy packaging and transportation.
- Protective end design of the handlebar for safety of the movement.

Arm Curl

PE108

Standard Weight Stack: 96 kg/212 lbs
 Optional Weight Stack: 123 kg/271 lbs
 Assembled Dimension: 151X144X160 cm
 Net Weight: 153 kg



- Articulating arm eliminates the need for adjustment while allowing users to move in a pattern best suited for their body type or motion preference.
- Rotating swivel grips allow for exercise variety.
- Arm pad is angled for stability, and limits unwanted shoulder movement during exercise.
- Optimized pivot location creates a biomechanically correct range of motion.
- Angled hand grips ensure optimal wrist position.
- Unique link-rod design ensures smooth range of motion.
- Strong and durable aluminum alloy shield frame.
- Equipped with convenient cup and cellphone holder.
- Separable structure design for easy packaging and transportation.
- Protective end design of the handlebar for safety of the movement.

Triceps Press

PE110

Standard Weight Stack: 66 kg/146 lbs
 Optional Weight Stack: 84 kg/185 lbs
 Assembled Dimension: 177.5X115.7X160 cm
 Net Weight: 164 kg



- Angled back pad reduces stress, improves stabilization and enhances comfort.
- Super-sized, dual position grips reduce pressure when pressing and create different hand positioning.
- The whole series are equipped with professional stable feet for safety.
- Professional and precise ergonomic design of training angles.
- Strong and durable aluminum alloy shield frame.
- Equipped with convenient cup and cellphone holder.
- Separable structure design for easy packaging and transportation.
- Protective end design of the handlebar for safety of the movement.

Pec Fly/Rear Delt

PE111

Standard Weight Stack: 96 kg/212 lbs
 Optional Weight Stack: 123 kg/271 lbs
 Assembled Dimension: 137.9×115.7×190.6 cm
 Net Weight: 148 kg



- The dual pivoting arms allow for users of different arm lengths to comfortably perform each exercise while maintaining proper posture.
- Easily adjustable dual hand position provides variety for both the pec and rear delt fly movements.
- Super-sized grips reduce pressure when pressing.
- The whole series are equipped with professional stable feet for safety.
- Professional and precise ergonomic design of training angles.
- Strong and durable aluminum alloy shield frame.
- Equipped with convenient cup and cellphone holder.
- Separable structure design for easy packaging and transportation.
- Protective end design of the handlebar for safety of the movement.

Leg Extension

PE201

Standard Weight Stack: 96 kg/212 lbs
 Optional Weight Stack: 123 kg/271 lbs
 Assembled Dimension: 125.2×129.5×159.6 cm
 Net Weight: 160 kg



- Angled seat and back pads encourage full quadriceps contraction.
- Thumb-switch controls and ergonomic adjustment handle allow easy user set-up.
- Easily adjustable starting position fits different users.
- Horizontally adjusting back pad helps help users find a natural and comfortable workout.
- Super-sized bearings create durable and smooth motion.
- The whole series are equipped with professional stable feet for safety.
- Professional and precise ergonomic design of training angles.
- Strong and durable aluminum alloy shield frame.
- Equipped with convenient cup and cellphone holder.
- Separable structure design for easy packaging and transportation.
- Protective end design of the handlebar for safety of the movement.

Lateral Raise

PE113

Standard Weight Stack: 66 kg/146 lbs
 Optional Weight Stack: 84 kg/185 lbs
 Assembled Dimension: 113.3×126.6×159.6 cm
 Net Weight: 140 kg

- Oversized arm pads enhance comfort and accommodate a variety of users.
- Padded arm pads and fixed handles allow for easy user positioning.
- Super-sized grips reduce pressure when pressing.
- The whole series are equipped with professional stable feet for safety.
- Professional and precise ergonomic design of training angles.
- Strong and durable aluminum alloy shield frame.
- Equipped with convenient cup and cellphone holder.
- Separable structure design for easy packaging and transportation.
- Protective end design of the handlebar for safety of the movement.



Prone Leg Curl

PE203

Standard Weight Stack: 66 kg/146 lbs
 Optional Weight Stack: 84 kg/185 lbs
 Assembled Dimension: 173.8×113.6×159.6 cm
 Net Weight: 160 kg

- Easily adjustable leg limiting pad helps users find the most comfortable starting position.
- Countered arms help users to support and isolate the lower body and direct the force to one area.
- The whole series are equipped with professional stable feet for safety.
- Professional and precise ergonomic design of training angles.
- Strong and durable aluminum alloy shield frame.
- Equipped with convenient cup and cellphone holder.
- Separable structure design for easy packaging and transportation.
- Protective end design of the handlebar for safety of the movement.



Hip Abduction

PE205

Standard Weight Stack: 66 kg/146 lbs
 Optional Weight Stack: 84 kg/185 lbs
 Assembled Dimension: 160X74X159.7 cm
 Net Weight: 135 kg

- Knee pads provide leg support and enhanced comfort.
- Weight stack positioned in front of the user acts as a shield, providing enhanced privacy.
- Well-designed rotating structure ensures comfortable and smooth movement.
- The whole series are equipped with professional stable feet for safety.
- Professional and precise ergonomic design of training angles.
- Strong and durable aluminum alloy shield frame.
- Equipped with convenient cup and cellphone holder.
- Separable structure design for easy packaging and transportation.
- Protective end design of the handlebar for safety of the movement.



Standing Calf

PE208

Standard Weight Stack: 114 kg/251 lbs
 Optional Weight Stack: 141 kg/311 lbs
 Assembled Dimension: 140X128X161 cm
 Net Weight: 165 kg

- Angled support handles enhance comfort.
- Easy get-in footplate and ergonomic shoulder pad design help users find correct positioning quickly.
- The whole series are equipped with professional stable feet for safety.
- Professional and precise ergonomic design of training angles.
- Strong and durable aluminum alloy shield frame.
- Equipped with convenient cup and cellphone holder.
- Separable structure design for easy packaging and transportation.
- Protective end design of the handlebar for safety of the movement.



Seated Leg Press

PE207

Standard Weight Stack: 123 kg/271 lbs
 Assembled Dimension: 170X118X160 cm
 Net Weight: 203 kg

- Articulating frame moves backward and tilts for greater range of motion at the hip and more complete training of the glutes and hamstrings.
- The large foot plate increases the variety of exercise possible.
- Big back pad and seat provide more stability and confidence for older and poorly balanced users.
- Counterbalance system provides consistent resistance at even the lowest weight selections.
- Seat back angle adjusts to five positions emphasizing comfort and greater hip range of motion.
- Safe and controlled squatting design after workout repeats.
- The seat and back pad can be adjusted according to the range of motion to match users with different heights.
- Link-rod and bearings design improve durability and smooth performance.
- Strong and durable aluminum alloy shield frame.
- Equipped with convenient cup and cellphone holder.
- Separable structure design for easy packaging and transportation.



Glute Extension

PE209

Standard Weight Stack: 96 kg/212 lbs
 Optional Weight Stack: 123 kg/271 lbs
 Assembled Dimension: 133X126.5X160 cm
 Net Weight: 140 kg

- Adjustable foot bar allows the user to choose the amount of knee extension desired for movement and optimal fit for all sizes.
- Adjustable abdominal support pad ensures correct exercise position and minimum back pressure.
- Curvilinear movement encourages full gluteal training without requiring the user to align the hip joint.
- 2:1 weight ratio for smaller increases between plates and faster movements.
- Unique micro-adjustable pivot point offers precise positioning for a variety of users.
- Large handlebar improves support and stability.
- Incremental adjustment for small weight gain.
- Strong and durable aluminum alloy shield frame.
- Equipped with convenient cup and cellphone holder.
- Separable structure design for easy packaging and transportation.





Hip Adduction

PE210

Standard Weight Stack: 66 kg/146 lbs
 Optional Weight Stack: 84 kg/185 lbs
 Assembled Dimension: 157.6X72X160 cm
 Net Weight: 138 kg

- Knee pads provide leg support and enhanced comfort.
- Weight stack positioned in front of the user acts as a shield, providing enhanced privacy.
- Easily adjustable starting position fits different users.
- Well-designed rotating structure ensures comfortable and smooth movement.
- The whole series are equipped with professional stable feet for safety.
- Professional and precise ergonomic design of training angles.
- Strong and durable aluminum alloy shield frame.
- Equipped with convenient cup and cellphone holder.
- Separable structure design for easy packaging and transportation.
- Protective end design of the handlebar for safety of the movement.

Torso Rotation

PE303

Standard Weight Stack: 96 kg/212 lbs
 Optional Weight Stack: 123 kg/271 lbs
 Assembled Dimension: 131X73X160 cm
 Net Weight: 142 kg

- Foot bar helps users of all sizes achieve proper stabilization.
- Contoured knee pads with wear covers enhance comfort, stability and durability.
- Easily adjusted starting position.
- Arm, seat and back pad positions help secure the user for maximized oblique muscle engagement.
- This unit provides resistance for rotation in both directions, providing a complete oblique workout.
- Easily adjustable starting position fits different users.
- Well-designed rotating structure ensures comfortable and smooth movement.
- Considerate pedal design allows users gain wider positioning area.
- The whole series are equipped with professional stable feet for safety.
- Professional and precise ergonomic design of training angles.
- Strong and durable aluminum alloy shield frame.
- Equipped with convenient cup and cellphone holder.
- Separable structure design for easy packaging and transportation.
- Protective end design of the handlebar for safety of the movement.



Abdominal

PE301

Standard Weight Stack: 96 kg/212 lbs
 Optional Weight Stack: 123 kg/271 lbs
 Assembled Dimension: 141.5X102.3X160 cm
 Net Weight: 130 kg

- Ergonomic back pad improves range of motion and enhances comfort.
- Countered arms help users support and isolate the lower body and direct the force to one area.
- Easily adjusted footpad accommodates users of different height.
- The whole series are equipped with professional stable feet for safety.
- Professional and precise ergonomic design of training angles.
- Strong and durable aluminum alloy shield frame.
- Equipped with convenient cup and cellphone holder.
- Separable structure design for easy packaging and transportation.
- Protective end design of the handlebar for safety of the movement.



Cable Cross

PE402

Standard Weight Stack: 2*96 kg/2*212 lbs
 Optional Weight Stack: 12*123 kg/2*271 lbs
 Assembled Dimension: 172X100X219 cm
 Net Weight: 190 kg

- 1:2 pulley ratio provides low incremental weight changes and moderate speed work.
- Space efficient, allows multiple users to exercise simultaneously.
- One-handed adjustment makes operation easy.
- Widely spaced, dual-adjustable pulleys offer exercise variety.
- Frame description standard rubber feet protect base of the frame and prevent the machine from slipping.
- Each frame receives an electrostatic powder coat finish to ensure maximum adhesion and durability.
- 11-gauge steel frame ensures maximum structural integrity.
- Super-sized grips reduce pressure when pressing.
- Separable structure design for easy packaging and transportation.



4-Stack

PE404

Standard Weight Stack: 4*96 kg/4*212 lbs
 Optional Weight Stack: 4*123 kg/4*271 lbs
 Assembled Dimension: 330X211X234.5 cm
 Net Weight: 337 kg

- Weight stacks allow multiple users to exercise simultaneously.
- Pull down, long pull, triceps push down and adjustable hi/lo pulley.
- Unilateral design allows single or dual-arm exercise.
- Space efficient and moveable.
- Frame description standard rubber feet protect base of the frame and prevent the machine from slipping.
- Each frame receives an electrostatic powder coat finish to ensure maximum adhesion and durability.
- 11-gauge steel frame ensures maximum structural integrity.
- Super-sized grips reduce pressure when pressing.
- Strong and durable aluminum alloy shield frame.
- Separable structure design for easy packaging and transportation.



Sover Machine

PE403

Standard Weight Stack: 2*96 kg/2*212 lbs
 Optional Weight Stack: 2*123 kg/2*271 lbs
 Assembled Dimension: 420.6X72X237 cm
 Net Weight: 250 kg



6-Stack

PE406

Standard Weight Stack: 5*96 kg/5*212 lbs
 Optional Weight Stack: 5*123 kg/5*271 lbs
 Assembled Dimension: 520x330x237 cm
 Net Weight: 477 kg

9-Stack

PE409

Standard Weight Stack: 8*96 kg/8*212 lbs
 Optional Weight Stack: 8*123 kg/8*271 lbs
 Assembled Dimension: 618X330X237 cm
 Net Weight: 704 kg





PISTON-S SERIES



Multi Press (Chest/Shoulder)

PS01

Standard Weight Stack: 96 kg/212 lbs
Optional Weight Stack: 123 kg/271 lbs
Assembled Dimension: 177.9X151X159.6 cm
Net Weight: 168 kg

- Designed for easy entry and exit.
- Smoothly transition between exercises with one simple adjustment.
- Dual-position hand grips allow for greater training variety.
- The whole series are equipped with professional stable feet for safety.
- Professional and precise ergonomic design of training angles.
- Strong and durable aluminum alloy shield frame.
- Equipped with convenient cup and cellphone holder.
- Separable structure design for easy packaging and transportation.
- Protective end design of the handlebar for safety of the movement.

Bicep Curl/ Tricep Extension

PS03

Standard Weight Stack: 66 kg/146 lbs
Optional Weight Stack : 84 kg/185 lbs
Assembled Dimension: 119.5X120X159.6 cm
Net Weight: 133 kg

- Upper-arm pads are angled to enhance user stability during exercise.
- Two machines in one: bicep curl and tricep extension. Preacher curl position with auto-adjust hand grips to fit all users.
- Ergonomic adjustable roller helps users to find the most comfortable position and bring excellent path of motion.
- The whole series are equipped with professional stable feet for safety.
- Professional and precise ergonomic design of training angles.
- Strong and durable aluminum alloy shield frame.
- Equipped with convenient cup and cellphone holder.
- Separable structure design for easy packaging and transportation.
- Protective end design of the handlebar for safety of the movement.



Pulldown/Seated Row

PS02

Standard Weight Stack: 96 kg/212 lbs
Optional Weight Stack: 123 kg/271 lbs
Assembled Dimension: 173X156.5X230.2 cm
Net Weight: 157 kg

- Elevated foot rests provide stability and comfort during heavy lifts.
- The row bar rests on a storage plate with a protective coating so that the bar is out of the way when the Pulldown is being used. The protective coating keeps the storage plate from scratches and dents.
- Easily adjustable roller helps users find out the most comfortable position.
- The whole series are equipped with professional stable feet for safety.
- Professional and precise ergonomic design of training angles.
- Strong and durable aluminum alloy shield frame.
- Equipped with convenient cup and cellphone holder.
- Separable structure design for easy packaging and transportation.
- Protective end design of the handlebar for safety of the movement.



Leg Extension/ Leg Curl

PS04

Standard Weight Stack: 96 kg/212 lbs
Optional Weight Stack: 123 kg/271 lbs
Assembled Dimension: 146X122.4X159.6 cm
Net Weight: 160 kg

- Angled pads and ideal pivot location promote full muscle contraction.
- The start position and roller pads easily adjust from the seated position making it easier for the user to get in and fit the unit to their needs once seated.
- Easily adjustable roller helps users find the most comfortable position.
- Parallel movement arms ensure smooth range of motion.
- The whole series are equipped with professional stable feet for safety.
- Professional and precise ergonomic design of training angles.
- Strong and durable aluminum alloy shield frame.
- Equipped with convenient cup and cellphone holder.
- Separable structure design for easy packaging and transportation.
- Protective end design of the handlebar for safety of the movement.





Inner/Outer

PS05

Standard Weight Stack: 66 kg/146 lbs
 Optional Weight Stack: 84 kg/185 lbs
 Assembled Dimension: 157.7X162.8X159.6 cm
 Net Weight: 155 kg

- Easily adjustable leg limiting pad allows users to choose different workouts.
- Dual foot pad fits people of different heights.
- High quality super-sized bearings bring excellent performance.
- Precision machined pulley leads smoother path of motion.
- Durable EXERFLEXPRO® cable ensures workout experience and unparalleled safety.
- Heavy duty translucent shield provides privacy and safety.
- Instructional placard guides users the best workout results with correct illustrations.
- The whole series are equipped with professional stable feet for safety.
- Professional and precise ergonomic design of training angles.
- Strong and durable aluminum alloy shield frame.
- Equipped with convenient cup and cellphone holder.
- Separable structure design for easy packaging and transportation.
- Protective end design of the handlebar for safety of the movement.



Abdominal/ Back Extension

PS06

Standard Weight Stack : 66 kg/146 lbs
 Optional Weight Stack : 84 kg/185 lbs
 Assembled Dimension : 127.5X130X159.6 cm
 Net Weight: 143 kg

- Ergonomic adjustable roller helps users find the most comfortable position.
- Dual foot pad fits people of different heights.
- High quality super-sized bearings bring excellent performance.
- Precision machined pulley leads smoother path of motion.
- Durable EXERFLEXPRO® cable ensures workout experience and unparalleled safety.
- Heavy duty translucent shield provides privacy and safety.
- Instructional placard guides users the best workout results with correct illustrations.
- The whole series are equipped with professional stable feet for safety.
- Professional and precise ergonomic design of training angles.
- Strong and durable aluminum alloy shield frame.
- Equipped with convenient cup and cellphone holder.
- Separable structure design for easy packaging and transportation.
- Protective end design of the handlebar for safety of the movement.





TITAN SERIES



Chest Press

T01

Assembled Dimension: 153.1×215.8×179.2 cm
Net Weight: 185 kg

- Designed for maximum chest and shoulder muscle recruitment
- Converging axis arms bring natural and soft movement.
- Maintenance-free, reduces operating costs.
- The whole series are equipped with professional stable feet for safety.
- Professional and precise ergonomic design of training angles.
- Strong and durable aluminum alloy shield frame.
- Equipped with convenient cup and cellphone holder.
- Separable structure design for easy packaging and transportation.
- Anti-drop and rust-proof high-level aluminum alloy handlebar. Protective end design of the handlebar for safety of the movement.

Pulldown

T02

Assembled Dimension: 178×156.1×189.2 cm
Net Weight: 178 kg

- Diverging independent arms provide a natural path of motion.
- Multi grip handles provide exercise variety.
- Maintenance-free, reduces operating costs.
- The whole series are equipped with professional stable feet for safety.
- Professional and precise ergonomic design of training angles.
- Strong and durable aluminum alloy shield frame.
- Equipped with convenient cup and cellphone holder.
- Separable structure design for easy packaging and transportation.
- Anti-drop and rust-proof high-level aluminum alloy handlebar. Protective end design of the handlebar for safety of the movement.



Unique Better: Linking Rod Design



The unique design working out more scientific. The load-bearing achieves a peak change. It is more reasonable than the traditional non-link design, achieving the similar performance and effect of cable exercise equipment.

Shoulder Press

T03

Assembled Dimension: 135.3×191.4×114.2 cm
Net Weight: 165 kg

- 4 integrated weight-storage horns
- Maintenance-free, reduces operating costs
- The whole series are equipped with professional stable feet for safety.
- Professional and precise ergonomic design of training angles.
- Strong and durable aluminum alloy shield frame.
- Equipped with convenient cup and cellphone holder.
- Separable structure design for easy packaging and transportation.
- Anti-drop and rust-proof high-level aluminum alloy handlebar. Protective end design of the handlebar for safety of the movement.





Seated Row

T04

Assembled Dimension: 155.2×147×122.8 cm
Net Weight: 146 kg

- Foot plate and chest pad for stabilization and greater muscle recruitment.
- Diverging independent arms provide a natural path of motion.
- Multi-grip positions offer greater training variety.
- Maintenance-free, reduces operating costs.
- Dual position grips create different hand positioning.
- The whole series are equipped with professional stable feet for safety.
- Professional and precise ergonomic design of training angles.
- Strong and durable aluminum alloy shield frame.
- Equipped with convenient cup and cellphone holder.
- Separable structure design for easy packaging and transportation.
- Anti-drop and rust-proof high-level aluminum alloy handlebar.
- Protective end design of the handlebar for safety of the movement.

Leg Extension

T05

Assembled Dimension: 163.7×141.6×110.9 cm
Net Weight: 122 kg

- Maintenance-free, reduces operating costs.
- Ergonomic and comfort leg roller pad brings excellent path of motion.
- The whole series are equipped with professional stable feet for safety.
- Professional and precise ergonomic design of training angles.
- Strong and durable aluminum alloy shield frame.
- Equipped with convenient cup and cellphone holder.
- Separable structure design for easy packaging and transportation.
- Anti-drop and rust-proof high-level aluminum alloy handlebar.
- Protective end design of the handlebar for safety of the movement.



Seated Calf Raise

T06

Assembled Dimension: 143.3×75.9×113.2 cm
Net Weight: 70 kg

- Maintenance-free, reduces operating costs.
- The seated design of this Calf Raise eliminates compression of the spine, providing a more effective and comfortable workout.
- The adjustable thigh pads allow users of all sizes to fit this unit to their needs.
- Ergonomic design of adjustable leg limiting pad isolates the lower body and directs the force to one area.
- The whole series are equipped with professional stable feet for safety.
- Professional and precise ergonomic design of training angles.
- Strong and durable aluminum alloy shield frame.
- Equipped with convenient cup and cellphone holder.
- Separable structure design for easy packaging and transportation.
- Anti-drop and rust-proof high-level aluminum alloy handlebar.
- Protective end design of the handlebar for safety of the movement.



PISTON - E

BENCH SERIES





Olympic Flat Bench
PEB101

Assembled Dimension:
188×155×130 cm
Net Weight: 80 kg



Olympic Incline Bench
PEB102

Assembled Dimension:
196×190×148 cm
Net Weight: 103 kg



Olympic Decline Bench
PEB103

Assembled Dimension:
196.2×190×128.8 cm
Net Weight: 95 kg



Dumbbell Rack 3 Tier-9
PEB112-9

Assembled Dimension:
212×59.4×93.2 mm
Net Weight: 94 kg



Utility Bench
PEB116

Assembled Dimension:
93.8×67×106 cm
Net Weight: 24 kg



Portal Frame
PEB117

Assembled Dimension:
220.4×156×233.5 cm
Net Weight: 275 kg



Plate Rack
PEB118

Assembled Dimension:
83×67×114 cm
Net Weight: 28 kg



Multi-Adjustable Bench
PEB104

Assembled Dimension:
153.8×67×126.5 cm
Net Weight: 40 kg



Abdominal Bench
PEB106

Assembled Dimension:
154×68×100 cm
Net Weight: 50 kg



Back Extension
PEB107

Assembled Dimension:
138×75.5×88.5 cm
Net Weight: 60 kg



Small Bar Rack
PEB119

Assembled Dimension:
100×92.3×163.5 cm
Net Weight: 60 kg



Kettle Bell Rack- 2 Tier
PEB121

Assembled Dimension:
161×55×72 cm
Net Weight: 60 kg



Bar Rack
PEB124

Assembled Dimension:
86×48×24 cm
Net Weight: 24 kg



Dip station
PEB108

Assembled Dimension:
127×124×235 cm
Net Weight: 110 kg



Scott
PEB109

Assembled Dimension:
125.7×85×94.8 cm
Net Weight: 48 kg



Flat Bench
PEB110

Assembled Dimension:
125.6×67×43 cm
Net Weight: 24 kg



Smith Machine
PEB201

Assembled Dimension:
217×132×229 cm
Net Weight: 196 kg



Leg Press Machine
PEB203

Assembled Dimension:
223×166×147 cm
Net Weight: 220 kg



Plate Loaded Squat
PEB204

Assembled Dimension:
202×166×148 cm
Net Weight: 240 kg



Dumbbell Rack 2 Tier-6
PEB111-6

Assembled Dimension:
152.5×53.9×71.2 cm
Net Weight: 57 kg



Dumbbell Rack 3 Tier-6
PEB112-6

Assembled Dimension:
152.5×62.2×93.2 cm
Net Weight: 68 kg



Dumbbell Rack 2 Tier-9
PEB111-9

Assembled Dimension:
212×51.1×71.2 cm
Net Weight: 76 kg



Small Squat Rack
PEB205

Assembled Dimension:
156×123.5×185.6 cm
Net Weight: 80 kg



Extension
PEB301

Assembled Dimension:
126×68×119 cm
Net Weight: 50 kg

TREADMILL



Specifications	A15	A13
Console Screen	21.5" Touchscreen	0.56" Led+8*8 Dot Matrix
Motor Power	3.0KW	3.0KW
Speed	1-24KM/H	1-24KM/H
Incline	0-15%	0-15%
Running Surface	580*1600mm	580*1600mm
Assembled Dimension	2220*910*1600mm	2220*910*1600mm
Self-compiled Programs	3	3
Preset Programs	6	6
Power Requirements	AC 220V/110V	AC 220V/110V
Net Weight/Gross Weight	240KG	240KG
Max User Weight	150KG	150KG
Console Function		
USB	•	○
Headphone	•	-
Fan	•	•
Multiple Cup And Accessory Holders	•	•
Bluetooth Audio Output	•	-
Console Data Display		
Speed	•	•
Incline	•	•
Speed Shortcut Key	•	•
Slope Shortcut Key	•	•
Calories	•	•
Heart Rate	•	•
Distance	•	•
Time	•	•
Frequency	•	•
Power Ration	•	•
Remaining Time	•	•
Elapsed Time	•	•
Total Progress Time	•	•
Rotations Per Minute	•	•
Average Speed	•	•
METS	•	•
Preset Programs	•	•
Self-compiled	•	•

ELLIPTICAL



Specifications	A15	A13
Console Screen	10.1" Touchscreen	0.56" Led+8*8 Dot Matrix
Resistance Level	1-25	1-25
Stride Grade	1-10	1-10
Step Depth Grade	1-15	1-15
Stride Adjustment Length	481-637mm	481-637mm
Step Depth Adjustment Length	435-561mm	435-561mm
Pedal Center Distance	230mm	230mm
Self-compiled Programs	1	1
Preset Programs	6	6
Power Requirements	AC 100V~240V 50/60Hz	AC 100V~240V 50/60Hz
Assembled Dimension	2120*790*1680mm	2120*790*1680mm
Net Weight/Gross Weight	225/310KG	225/310KG
Max User Weight	150KG	150KG
Console Function		
USB	•	○
Headphone	•	-
Fan	•	•
Multiple Cup And Accessory Holders	•	•
Bluetooth Audio Output	•	-
Mobile and Pad Holders	•	•
Console Data Display		
Resistance Level	•	•
Stride Adjustment	•	•
Step Depth Adjustment	•	•
Speed	•	•
Rotations Per Minute	•	•
Average Speed	•	•
Calories	•	•
Heart Rate	•	•
Distance	•	•
Time	•	•
Frequency	•	•
Power Ration	•	•
Remaining Time	•	•
Elapsed Time	•	•
Total Progress Time	•	•
Preset Programs	•	•
Self-compiled	•	•
Function Feature		
Smart Stride Adjustment	•	•
Smart Step Depth Adjustment	•	•
Multiple Position Handrails	•	•
Quick Adjustable Handrail	•	•
Transportation Wheel	•	•

STAIRTRAINER



Specifications	A15	A13
Console Screen	10.1" Touchscreen	0.56" Led+8*8 Dot Matrix
Resistance Level	1-20	1-20
Staircase Dimension	550*278*205mm	550*278*205mm
Initial Stair Height	300mm	300mm
Effective Utilization Staircase	3	3
Self-compiled Programs	1	1
Preset Programs	6	6
Power Requirements	AC 100V~240V 50/60Hz	AC 100V~240V 50/60Hz
Assembled Dimension	1600*970*2230mm	1600*970*2230mm
Net Weight/Gross Weight	226/310KG	226/310KG
Max User Weight	150KG	150KG
Console Function		
USB	●	○
Headphone	●	-
Fan	●	●
Multiple Cup And Accessory Holders	●	●
Bluetooth Audio Output	●	-
Mobile and Pad Holders	●	●
Console Data Display		
Resistance Level	●	●
Speed	●	●
Rotations Per Minute	●	●
Average Speed	●	●
Calories	●	●
Heart Rate	●	●
Distance	●	●
Time	●	●
Frequency	●	●
Power Ration	●	●
Remaining Time	●	●
Elapsed Time	●	●
Total Progress Time	●	●
Preset Programs	●	●
Self-compiled	●	●
Function Feature		
Easily step into	●	●
Easily Step into	●	●
Patented Emergency Stop	●	●
Multiple Position Handrails	●	●
Quick Adjustable Handrail	●	●
Transportation Wheel	●	●

UPRIGHT BIKE



Specifications	A15	A13
Console Screen	10.1" Touchscreen	0.56" Led+8*8 Dot Matrix
Resistance Level	1-25	1-25
Self-compiled Programs	1	1
Preset Programs	6	6
Power Requirements	AC 100V~240V 50/60Hz	AC 100V~240V 50/60Hz
Assembled Dimension	1200*500*1450mm	1200*500*1450mm
Net Weight/Gross Weight	75/95KG	75/95KG
Max User Weight	150KG	180KG
Console Function		
USB	●	○
Headphone	●	-
Fan	●	●
Multiple Cup And Accessory Holders	●	●
Bluetooth Audio Output	●	-
Mobile and Pad Holders	●	●
Console Data Display		
Resistance Level	●	●
Speed	●	●
Rotations Per Minute	●	●
Average Speed	●	●
Calories	●	●
Heart Rate	●	●
Distance	●	●
Time	●	●
Frequency	●	●
Power Ration	●	●
Remaining Time	●	●
Elapsed Time	●	●
Total Progress Time	●	●
Preset Programs	●	●
Self-compiled	●	●
Function Feature		
Multiple Position Handrails	●	●
Quick Adjustable Handrail	●	●
Adjustable Pedal	●	●
Adjustable Seat	●	●
Transportation Wheel	●	●



Measurement (W x L x H)	650 x 640 x 215 mm
Weight	39 kg
Maximum user weight	120 kg
Vibration area	650 x 640 mm
Vibrationplate Thickness	5,8 mm
Vibration Frequencies	30-50 HZ, 1Hz gradually
Vibration speeding up	Factor 1-5
Display measurement	LED
Data transfer	Phone - Display
Preset Programs	Strength \ Stretch \ Massage \ Relax

PISTON-E

EN957

PISTON 5

	PE101	PE102	PE104	PE105
	Chest Press	Shoulder Press	Pulldown	Dip/Chin Assistant
Standard Weight Stack:	96 kg / 212 lbs	96 kg/212 lbs	96 kg / 212 lbs	141 kg/311 lbs
Optional Weight Stack:	123 kg / 271 lbs	—	123 kg / 271 lbs	—
Assembled Dimension:	122.5×147.7×179.6 cm	162.4×159.2×159.6 cm	166.8×125.4×193.0 cm	158.7×131.6×251.6 cm
Net Weight:	165 kg	170 kg	162 kg	140 kg

	PE107	PE108	PE109	PE110
	Seated Row	Arm Curl	Converging Chest Press	Triceps Press
Standard Weight Stack:	96 kg / 212 lbs	96 kg/212 lbs	96 kg / 212 lbs	66 kg/146 lbs
Optional Weight Stack:	123 kg / 271 lbs	123 kg/271 lbs	123 kg / 271 lbs	84 kg/185 lbs
Assembled Dimension:	193×111.5×160 cm	151X144X160 cm	140X130X160 cm	177.5×115.7×159.6 cm
Net Weight:	155 kg	153 kg	158 kg	164 kg

	PE111	PE113	PE201	PE203
	Pec Fly/Rear Delt	Lateral Raise	Leg Extension	Prone Leg Curl
Standard Weight Stack:	96 kg / 212 lbs	66 kg/146 lbs	96 kg/212 lbs	66 kg/146 lbs
Optional Weight Stack:	123 kg / 271 lbs	84 kg/185 lbs	123 kg/271 lbs	84 kg/185 lbs
Assembled Dimension:	137.9×115.7×190.6 cm	113.3×126.6×159.6 cm	125.2×129.5×159.6 cm	173.8×113.6×159.6 cm
Net Weight:	148 kg	140 kg	160 kg	160 kg

	PE205	PE207	PE208	PE209
				
	Hip Abduction	Seated Leg Press	Standing Calf	Glute Extension
Standard Weight Stack:	66 kg/146 lbs	123 kg/271 lbs	114 kg/251 lbs	96 kg/212 lbs
Optional Weight Stack:	84 kg/185 lbs	—	141 kg/311 lbs	123 kg/271 lbs
Assembled Dimension:	155X69X160 cm	70X118X160 cm	140X128X161 cm	133X126.5X160 cm
Net Weight:	123 kg	203 kg	165 kg	140 kg

	PE210	PE301	PE303	PE402
				
	Hip Adduction	Abdominal	Torso Rotation	Cable Cross
Standard Weight Stack:	66 kg/146 lbs	96 kg/212 lbs	96 kg/212 lbs	96 kg/212 lbs
Optional Weight Stack:	84 kg/185 lbs	123 kg/271 lbs	123 kg/271 lbs	123 kg/271 lbs
Assembled Dimension:	157.6X72X159.6 cm	141.5X102.3X160 cm	131X73X160 cm	172X100X219cm
Net Weight:	138 kg	130 kg	142 kg	190 kg

PISTON 3

	PE403	PE404	PE406	PE409
				
	Sover Machine	4-Stack	6-Stack	9-Stack
Standard Weight Stack:	2*96 kg/2*212 lbs	4*96 kg/4*212 lbs	5*96 kg/5*212 lbs	8*96 kg/8*212 lbs
Optional Weight Stack:	2*123 kg/2*271 lbs	4*123 kg/4*271 lbs	5*123 kg/5*271 lbs	8*123 kg/8*271 lbs
Assembled Dimension:	420.6X72X237 cm	330X211X234.5 cm	520X330X237 cm	618X330X237 cm
Net Weight:	250 kg	337 kg	477 kg	704 kg

PISTON-S

EN957

PISTON 5

	PS01	PS02	PS03	PS04
				
	Multi Press (Chest/Shoulder)	Pulldown/ Seated Row	Bicep Curl/ Tricep Extension	Leg Extension/ Leg Curl
Standard Weight Stack:	96 kg/212 lbs	96 kg/212 lbs	66 kg/146 lbs	96 kg/212 lbs
Optional Weight Stack:	123 kg/271 lbs	—	84 kg/185 lbs	123 kg/271 lbs
Assembled Dimension:	177.9X151X159.6 cm	173X156.5X230.2 cm	119.5X120X159.6 cm	146X122.4X159.6 cm
Net Weight:	168 kg	157 kg	133 kg	160 kg

	PS05	PS06
		
	Inner/Outer	Abdominal/ Back Extension
Standard Weight Stack:	66 kg/146 lbs	66 kg/146 lbs
Optional Weight Stack:	84 kg/185 lbs	84 kg/185 lbs
Assembled Dimension:	157.7X162.8X159.6 cm	127.5X130X159.6 cm
Net Weight:	155 kg	143 kg

TITAN

EN957

	T01	T02	T03	T04
				
	Chest Press	Pulldown	Shoulder Press	Seated Row
Assembled Dimension:	153.1X215.8X179.2 cm	178X156.1X189.2 cm	135.3X191.4X114.2 cm	155.2X147X122.8 cm
Net Weight:	185 kg	178 kg	165 kg	146 kg

	T05	T06
		
	Leg Extension	Seated Calf Raise
Assembled Dimension:	163.7×141.6×110.9 cm	143.3×75.9×113.2 cm
Net Weight:	122 kg	70 kg

BENCH

EN957

	PEB101	PEB102	PEB103	PEB104
				
	Olympic Flat Bench	Olympic Incline Bench	Olympic Decline Bench	Multi-Adjustable Bench
Assembled Dimension:	188×155×130 cm	195.7×132×146 cm	196.2×132×128.8 cm	153.8×67×126.5 cm
Net Weight:	80 kg	103 kg	95 kg	40 kg
	PEB106	PEB107	PEB108	PEB109
				
	Abdominal Bench	Back Extension	Dip station	Scott
Assembled Dimension:	154×68×100 cm	138×75.5×88.5 cm	127×124×235 cm	125.7×85×94.8 cm
Net Weight:	50 kg	60 kg	110 kg	48 kg
	PEB110	PEB111-6	PEB112-9	PEB111-9
				
	Flat Bench	Dumbbell Rack 2 Tier-6	Dumbbell Rack 3 Tier-9	Dumbbell Rack 2 Tier-9
Assembled Dimension:	125.6×67×43 cm	152.5×53.9×71.2 cm	152.5×62.2×93.2 cm	212×51.1×71.2 cm
Net Weight:	24 kg	57 kg	68 kg	76 kg

	PEB112-9	PEB116	PEB117	PEB118
				
	Dumbbell Rack 3 Tier-9	Utility Bench	Portal Frame	Plate Rack
Assembled Dimension:	212×59.4×93.2 mm	93.8×67×106 cm	100×92.3×163.5 cm	83×67×114 cm
Net Weight:	94 kg	24 kg	275 kg	28 kg
	PEB119	PEB121	PEB124	PEB201
				
	Small Bar Rack	Kettle Bell Rack- 2 Tier	Bar Rack	Smith Machine
Assembled Dimension:	100×92.3×163.5 cm	161×55×72 cm	86×48×24 cm	217×132×229 cm
Net Weight:	60 kg	60 kg	24 kg	196 kg
	PEB203	PEB204	PEB205	PEB301
				
	Leg Press Machine	Plate Loaded Squat	Small Squat Rack	Extension
Assembled Dimension:	1223×166×147 cm	202×166×148 cm	156×123.5×185.6 cm	126×68×119 cm
Net Weight:	220 kg	240 kg	80 kg	50 kg

DUMBBELL

EN957



Weight: 2.5 – 5 – 7.5 – 10 – 12.5 – 15 – 17.5 – 20 – 22.5 – 25 – 27.5 – 30 – 32.5 – 35KG



Maintenance

Strong ABS material, AnyFit one-shot molding technology, high toughness, impact resistance, improve the privacy and security.
Appearance design, structure without screw assembly and replacement process simple requirements into consideration. The process of maintenance and replacement becomes extremely convenient.



Quality

AnyFit strictly controls each production process, and the production line yield and unpacking yield are 100%, so the club does not need to update the equipment during the operation period. AnyFit equipment has passed the most of global certification and requirements.

Treadmill 150,000 times uninterrupted load testing. Climber 120,000 times uninterrupted load testing.
Elliptical 200,000 times uninterrupted load testing. Upright Bike 100,000 times uninterrupted load testing.
Strength 400,000 times uninterrupted load testing.

AnyFit has developed testing equipment and testing standards for different enterprises on the basis of equipment that meets the requirements of testing.
AnyFit aerobic equipment meets the caulking and surface color difference and other strict standards.



Service Guarantee

Platform:

AnyFit suite system can classify and manage the equipment of the club, check the status of the equipment, record the daily real-time operation data, check the historical data, set an automatic alarm for after-sales maintenance, fault, and forecast and remind the replacement of aging vulnerable parts.

Smart equipment classification management, each device has its unique identification code, according to the different types of aerobic equipment exercise classification management, the club can view the overall operation of various types of equipment, whether in use, whether normal operation, real-time operation current, voltage, whether full load operation. Once the equipment fails, the system will send a fault warning immediately, notify the after-sales service department of the fault code, have a rough judgment of the fault, and prompt the corresponding solution; Facilitate after-sales maintenance. For some vulnerable parts there will be historical cumulative data, in the specified time and mileage to make a replacement forecast. Analyze the usage frequency of the equipment, record the peak usage and idle time of the equipment every day, and help the club to optimize the equipment configuration.

1 day telephone response **2** days door-to-door service **5** days to solve the problem

AnyFit sets up service teams around the world to unify service standards.

After-sales Service



Original accessories:

Ensure that all accessories are directly ordered to the manufacturer, the quality of the original accessories to ensure the safety and reliability of the use of equipment. All engineers have been trained by the manufacturers assessment, to ensure their professional technology and product maintenance reliability;



Service hotline:

We have professional customer service staff to answer your after-sales service questions and provide corresponding solutions, to provide the most convenient and timely help for customer contact and emergency rescue.



Emergency rescue:

Set up customer emergency rescue service station to minimize equipment downtime.



Free Maintenance:

In order to provide more convenient service for customers, no fee will be charged for the initial maintenance of the failure in a specific area.



Regular interview:

For customer equipment, AnyFit will implement the dynamic tracking system, periodically in the equipment to people's visit to the interview, telephone interviews, letters and so on, to achieve the small monitoring in the whole process of the intermittent period, and will provide equipment assessment and advice, in order to maximize the predicted failure and reduce equipment downtime cycle.



Customer feedback:

AnyFit will also establish a new customer feedback system. Please put forward your valuable opinions and suggestions and send them back to the personnel directly. Your opinions and Suggestions will be the direction of improvement of the bidder.



Equipment self-test:

The smart system equipped within the equipment has self-test function and alarm failure;



Smart online:

AnyFit product with smart teaching platform with smart online services.



Warranty

AnyFit warrants the equipment to be free from defects in materials and manufacture for the warranty periods set forth below. The warranty periods commence on the invoice date of original purchase. This warranty applies only against defects discovered within the warranty periods and extends only to the original purchaser of the product. Parts repaired or replaced under the terms of this warranty will be warranted for the remainder of the original warranty period only. To make a claim under warranty, the buyer must notify AnyFit or his or her authorized AnyFit distributor within 30 days after the date of discovery of any nonconformity and make the affected product available for inspection by AnyFit or its service representative. AnyFit's obligations under this warranty are limited as set forth below.

Warranty Periods and Coverage

Cardio

- Structural Frame: 10 years
- Motor: 8 years
- Generator/EMS/ECB brake: 2 years
- Key Pad: 1 year
- High Wear Console Items, including: Headphone Jacks, USB Connectors: 180 days
- Batteries, Non-integrated Receivers: 1 year
- Running belt, running deck, transmission belt: 3 years
- Motor controller: 3 years
- Screen: 2 years
- Mechanical and Electrical Parts (including PVS, transmitters): 2 years
- Media Receiver Boxes: 2 years

Strength

- Structural Moving Parts (weight plate, accessories, weight stacks): 3 years
- Hand Grips, Seat Adjustment Device, Cover, and Springs: 1 year
- Upholstery: 180 days
- Bearing: 3 years
- Structural Frameworks: 10 years
- Pulley Set (including steel cable): 3 years
- Coating: 180 days

• AnyFit reserves the right of interpretation.